

## Specifications

# SMART Room System™ for Microsoft® Lync® for large rooms

Model SRS-LYNC-L-G5 featuring two SMART Board® 8065i-G5 interactive flat panels

## Overview

The SMART Room System™ for Microsoft® Lync® for large rooms features two SMART Board® 8065i-G5 interactive flat panels, a tabletop console, a high-definition camera, table microphones and speakers. This room system is intended for 300 sq. ft. (28 m<sup>2</sup>) rooms and approximately 16 people.

Using the installed Lync Room System software, you can start a meeting and connect with other participants or meeting rooms with a single tap on the console or one of the interactive flat panels. You can write or draw on an interactive flat panel using the whiteboard feature, present a PowerPoint® slide show, connect a laptop or room computer, and share your content with connected participants and meeting rooms in real time.

See [smarttech.com/smartroom](http://smarttech.com/smartroom) for more information on this product.



## Dimensions and weights<sup>1</sup>

### Wall mounted interactive flat panels (with camera and speakers)

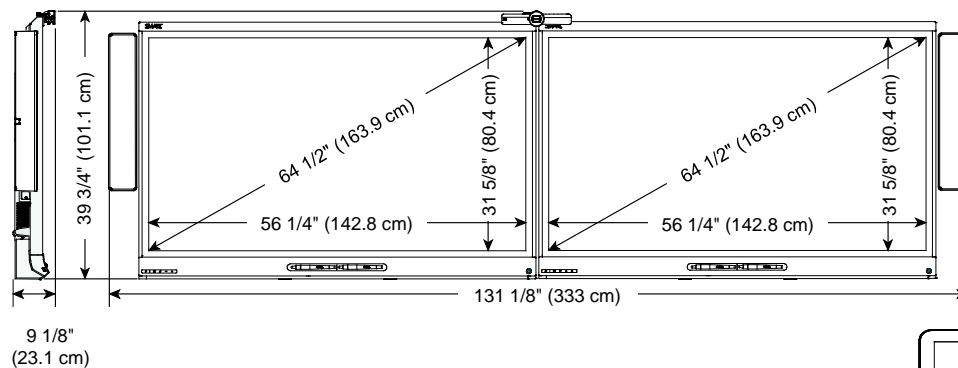

### Table microphone

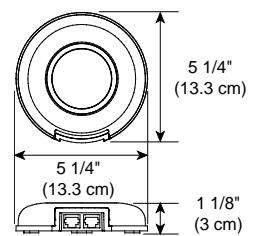

### Console

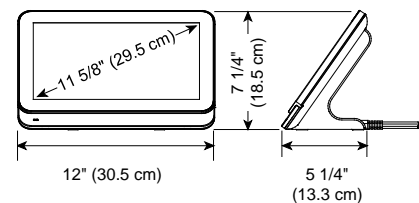

<sup>1</sup>All dimensions ± 1/8" (0.3 cm). All weights ± 2 lb. (0.9 kg).

SPECIFICATIONS

SMART ROOM SYSTEM FOR MICROSOFT LYNC FOR LARGE ROOMS – MODEL SRS-LYNC-L-G5 (2 × SBID8065I-G5)

	Weight	Shipping weight	Shipping dimensions
<b>Interactive flat panel (×2)</b>	137 lb. (62.2 kg)	181 lb. (82.3 kg)	69 1/4" × 49 5/8" × 11 7/8" (175.8 cm × 126.1 cm × 30.3 cm)
<b>WM-SBID-501 wall mount (×2)</b>	24 lb. (10.9 kg)	31 lb. (14 kg)	46" × 12 1/2" × 11" (117 cm × 32 cm × 28.1 cm)
<b>Speakers</b>	15 lb. (7 kg)	20 lb. (9.1 kg)	37 3/4" × 15 1/2" × 7 3/8" (96 cm × 39.5 cm × 18.8 cm)
<b>System components</b>	14 lb. (6.2 kg)	24 lb. (10.8 kg)	19 1/2" × 18" × 22 1/2" (49.5 cm × 45.7 cm × 57.2 cm)
<b>Total</b>	<b>351 lb. (159.4 kg)</b>	<b>508 lb. (230.6 kg)<sup>2</sup></b>	

Hardware

Included hardware

SBID8065i-G5	SMART Board 8065i-G5 interactive flat panel (×2)
AM70-L	Lync appliance
AM-ENC-L	Lync appliance enclosure
CP311	Console
CAM301	Camera
MIC500	Table microphone (×2)
MIX500	Audio processor
CSR500	Speakers
WM-SBID-501	Wall mount for installing an interactive flat panel on a wall (×2)
SRS-ACC-BK2	Accessory bracket kit
SRS-USB Bridge	SMART Room System USB Bridge

Included cables

For interactive flat panels	8' (2.4 m) IEC 60320 C13 to country-specific power (×2) 20' 8" (6.3 m) HDMI® (×2) 16' 5" (5 m) USB (×2)	
For Lync appliance	8' (2.4 m) IEC 60320 C13 to country-specific power 5' 4" (1.6 m) AC/DC converter	
For console	20' 8" (6.3 m) HDMI and USB 8' (2.4 m) IEC 60320 C13 to country-specific power 5' 4" (1.6 m) AC/DC converter	

<sup>2</sup>Including the pallet

## SMART ROOM SYSTEM FOR MICROSOFT LYNC FOR LARGE ROOMS – MODEL SRS-LYNC-L-G5 (2 × SBID8065I-G5)

For camera	9' 10" (3 m) USB 6' 7" (2 m) IEC 60320 C7 to country-specific power 4' 11" (1.5 m) AC/DC converter
For table microphones and audio processor	30' (9 m) audio (interactive flat panel to table) 13' (4 m) audio (microphone to microphone) 6' (1.8 m) USB 6' 7" (2 m) IEC 60320 C7 to country-specific power 4' 11" (1.5 m) AC/DC converter
For speakers	6' (1.8 m) dual RCA 16' 5" (5 m) audio (speaker to speaker) 6' 7" (2 m) IEC 60320 C7 to country-specific power 4' 11" (1.5 m) AC/DC converter
For laptop <sup>3</sup>	30' 6" (9.3 m) harness (HDMI and VGA)
For USB bridge	22' (6.7 m)
<b>Recommended diameter for conduit</b>	1 3/4" (4.5 cm)
<b>Interactive flat panels</b>	
Touch technology	DViT® (Digital Vision Touch) technology
Presence detection	One presence detection sensor on the bottom frame
Screen size (diagonal)	64 1/2" (163.9 cm)
Aspect ratio	16:9
Optimal resolution	3840 × 2160 (display only) 1920 × 1080 (with Lync appliance)
Vertical frequency	24–120 Hz
Contrast ratio (typical)	1400:1
Brightness (typical)	280–360 cd/m <sup>2</sup>
Pixel pitch	0.372 mm
<b>Lync appliance</b>	
Processor	2.3 GHz Intel® Core™ i7 with Intel HD 4000 graphics chipset
RAM	Dual-channel 8 GB DDR3
<b>Console</b>	
Screen size (diagonal)	11 5/8" (29.5 cm)
Aspect ratio	16:9
Resolution	1366 × 768
Brightness	250 cd/m <sup>2</sup>

<sup>3</sup>Laptop not included

**Camera**

Features	Digital pan, tilt and zoom (DPTZ) Automatic white balance Automatic exposure and power line frequency detection Manual lens tilt adjustment Internal privacy shutter Video recording indicator
----------	---------------------------------------------------------------------------------------------------------------------------------------------------------------------------------------------------------------

Aspect ratio	16:9
--------------	------

Resolution (maximum)	1920 × 1080
----------------------	-------------

Frame rate (typical)	30 frames per second (at ≥ 200 lx)
----------------------	------------------------------------

Field of view	109° (full) 98° (horizontal)
---------------	---------------------------------

Depth of field	3'–33' (1–10 m)
----------------	-----------------

Signal-to-noise ratio (minimum)	33 dB at ≥ 50 lx 36 dB at ≥ 200 lx
---------------------------------	---------------------------------------

Dynamic range (minimum)	42 dB
-------------------------	-------

**Table microphones**

Features	Mute button and indicator 13' (4 m) cable between microphones Daisy-chain up to five microphones
----------	--------------------------------------------------------------------------------------------------------

Local talker audio level	60–65 dBA measured at 20" (0.5 m) 360°, 10' (3 m) range per unit
--------------------------	---------------------------------------------------------------------

**Speakers**

Total harmonic distortion	< 1% average < 3% maximum 80–10 kHz
---------------------------	-------------------------------------------

Frequency response	± 6 dB, 80–10 kHz
--------------------	-------------------

Nominal volume	76 dBSPL
----------------	----------

**Audio**

Echo cancellation	> 45 dB at nominal receive output level
-------------------	-----------------------------------------

**Software**

Lync Room System software	See <a href="http://lync.microsoft.com">lync.microsoft.com</a>
---------------------------	----------------------------------------------------------------

## Storage and operating requirements

### Room system power (excluding console)

Power requirements	9.5A at 100V to 4A at 240V AC, 50 Hz to 60 Hz
--------------------	-----------------------------------------------

Power consumption at 77°F (25°C)	950 W
----------------------------------	-------

### Console power

Normal power consumption	< 12 W (using the supplied 12V AC/DC converter)
--------------------------	-------------------------------------------------

Standby power consumption	< 0.6 W
---------------------------	---------

### Storage

Temperature	-4–140°F (-20–60°C)
-------------	---------------------

Humidity	5–95% relative humidity, non-condensing
----------	-----------------------------------------

### Operating

Temperature	41–95°F (5–35°C)
-------------	------------------

Humidity	10–80% relative humidity, non-condensing
----------	------------------------------------------

## Certification and compliance

<b>Regulatory certification</b> <sup>4</sup>	UL (U.S. and Canada), FCC, IC, RCM, NOM, CU, CB, VCCI, KC, CCC, PSB, BIS, PSE, KCC
----------------------------------------------	------------------------------------------------------------------------------------

### Environmental compliance

China	EIP
-------	-----

European Union	REACH, RoHS, WEEE, Battery and Packaging
----------------	------------------------------------------

U.S.	Packaging and Conflict Minerals
------	---------------------------------

## Purchasing information

### Order number

SRS-LYNC-L-G5	SMART Room System for Lync for large rooms
---------------	--------------------------------------------

### Optional accessories

MIC500	Additional table microphone
--------	-----------------------------

WSK-DUAL	Wall stand kit for rooms with two interactive flat panels, including a cable raceway and two wall stands for transferring some of the interactive flat panels' weight to the floor
----------	------------------------------------------------------------------------------------------------------------------------------------------------------------------------------------

<sup>4</sup>As applicable to the components

## Warranty and support information

### Warranty

Two-year warranty	Interactive flat panels Camera Lync appliance Console
One-year warranty	Speakers Wall mounts
90-day return	Cables, pens and other items that can be purchased from the Store for SMART Parts (see <a href="http://smarttech.com/Support/PartsStore">smarttech.com/Support/PartsStore</a> ).

### SMART services for SMART Room System for Microsoft Lync

Network check	A remotely delivered pre-deployment assessment of your Lync-related IT environment to ensure optimization for the SMART Room System (see <a href="#">SMART Network Readiness Check</a> )
Usage reporting	A cloud-based service that shows the SMART Room System's usage on an intuitive dashboard, helping you manage deployments and accelerate adoption to maximize ROI (see <a href="#">SMART Usage Reporting</a> )
Proactive monitoring	A cloud-based service that provides 24/7 monitoring of the SMART Room System's usage, health and quality of experience and that sends proactive alerts at the earliest stage of a technical issue to minimize downtime (see <a href="#">SMART Proactive Monitoring</a> )

### SMART advanced support

Designed to limit downtime and optimize return on investment, SMART Support Services provide peace of mind and maximize the performance of your SMART solution. These offerings give you access to expert support, guaranteed response times and advance hardware replacement, reducing downtime and costs. Three service offerings are available: Basic, Elite and Platinum. For more information, see the [SMART Support Quick Reference Guide](#) or [smarttech.com/services](http://smarttech.com/services).

[smarttech.com/support](http://smarttech.com/support)  
[smarttech.com/support/entsupport](http://smarttech.com/support/entsupport)

© 2015 SMART Technologies ULC. All rights reserved. SMART Room System, SMART Board, DVIT, smarttech, the SMART logo and all SMART taglines are trademarks or registered trademarks of SMART Technologies ULC in the U.S. and/or other countries. Microsoft, Lync and PowerPoint are either registered trademarks or trademarks of Microsoft Corporation in the U.S. and/or other countries. "HDMI" and all associated logos are trademarks of HDMI Licensing, LLC. All other third-party product and company names may be trademarks of their respective owners. This product and/or use thereof is covered by one or more of the following U.S. patents: [www.smarttech.com/patents](http://www.smarttech.com/patents). Contents are subject to change without notice. 06/2015.