

PLEASE THINK BEFORE YOU PRINT

Specifications

SMART Podium™ interactive pen display

Models SP524-NB and SP524-MP

Physical specifications

Size	23 5/16" W × 15 13/16" H × 3" D (59.3 cm × 40.1 cm × 7.6 cm)
With adjustable stand (highest position)	23 5/16" W × 15 3/8" H × 10 3/4" D (59.3 cm × 39 cm × 27.3 cm)
Display area	21 5/16" W × 12 3/16" H (54.1 cm × 30.9 cm) 24" (61 cm) diagonal
Weight with adjustable stand	27 lb. 6 oz. (12.5 kg)
Shipping weight	30 lb. 13 oz. (14 kg)
Shipping size	26 1/2" W × 19 7/8" H × 10 1/2" D (67.7 cm × 50 cm × 26.9 cm)

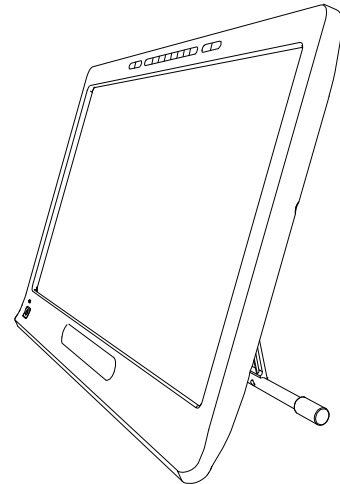

All dimensions +/- 1/8" (0.3 cm). All weights +/- 2 lb. (0.9 kg)

Standard features

System requirements	Supports Windows® operating systems and Mac OS operating system software. See smarttech.com/support for a complete list of system requirements.
SP524-NB	A DVD is included with your interactive pen display that contains SMART Notebook™ 10.8 collaborative learning software and SMART Product Drivers. Install the software and then register the interactive pen display at smarttech.com/registration to receive the product keys you need to activate the software.

Extraordinary made simple™

SMART™

SPECIFICATIONS

SMART Podium interactive pen display – Models SP524-NB and SP524-MP

SP524-MP The registration document in your product packaging includes instructions for registering your product online, which enables you to download and activate SMART Meeting Pro™ 2.3 software and SMART Product Drivers

HDCP Revision 1.3 compliant

Smooth Tilt Stand You can adjust the incline angle of the interactive pen display from a minimum position of 60° from vertical to a maximum position of 17.5° from vertical.

Mount Standard VESA® 100 mm rear mounting plate

Cables A DVI-D to DVI-D cable, a VGA to DVI-A cable and a USB-A to USB-B cable are included to connect your interactive pen display to your computer. A country-specific AC power cable to connect your interactive pen display to the power supply adapter is also included. You must provide the appropriate cables to connect your product to additional devices.

Power supply

Input 100V–240V AC, 50 Hz or 60 Hz

Output 12V DC, 5A, 60 W maximum

Power management The interactive pen display features an Energy Save mode. In this mode, the interactive pen display shuts off when it remains idle for the length of time you specify. You can then turn it on by pressing the power button.

Regulatory certification CB, CCC, CE, C-Tick, KC, FCC, NOM, UL, GOST-R, PSB, IRAM, TUV-GS, SASO

Environmental compliance EU Packaging, RoHS (Europe), Packaging, WEEE

Warranty Your interactive pen display has a two-year limited warranty. For details, see the warranty document included in the product packaging.

Interactive pen display features

Screen a-Si TFT active-matrix LCD display

Digitizing technology DVIT™ (Digital Vision Touch) technology

Communication interface USB 2.0 (high speed)

Aspect ratio Native 16:9 ratio. Supports 4:3 and 16:10 ratio with scaling.

Resolution 1080p (1920 × 1080)

Color depth 16.8 million

Synchronization range Vertical: 56 Hz
Horizontal: 76 Hz

SPECIFICATIONS

SMART Podium interactive pen display – Models SP524-NB and SP524-MP

IMPORTANT

Some Mac computers transmit video signals outside the 56 Hz–76 Hz synchronization range. You are unable to use these models with the SMART Podium interactive pen display.

Contrast ratio	580:1 (typical)
Brightness	Luminance of 180 cd/m ² (typical)
Viewing angle	Horizontal 170° and vertical 160° (typical)
Input video signal	Analog 0.7 Vp-p positive at 75 ohm
Auto adjustment	Fewer than 2 seconds
Display response time	5 milliseconds black-white response (typical)
Illuminated buttons	The buttons on the frame are backlit for easy recognition. When you press the Pen Color , Eraser or Select button, the backlight brightens to indicate the active button.
Backlight life	30,000 hours (nominal)
Tethered pen	Infrared, battery-free, tethered pen with a comfort grip
Magnetic pen tray	When not in use, the pen conveniently rests in the magnetic pen tray on the frame.
Maximum pen report rate	150 points per second
Power button	Solid green when the system is on, flashing green when the system is starting up and amber when the system is idle.
Status indicator light	Solid green when the system is communicating with SMART Product Drivers, flashing green when the system is in HID (mouse) mode and solid red when the interactive pen display isn't communicating with your computer.
Input/Output interface	
Video IN	DVI-I
Video OUT	DVI-I
USB B	USB 2.0 receptacle to connect the interactive pen display to your computer
USB A (×3)	USB 2.0 receptacle to connect a USB device such as a mouse, a keyboard or a USB drive.

NOTE

Prevent unauthorized data transfers by mechanically disabling the USB-A ports.

Security	Kensington® security slot
-----------------	---------------------------

SPECIFICATIONS

SMART Podium interactive pen display – Models SP524-NB and SP524-MP

Storage and operating specifications

Storage temperature	14°F to 140°F (-10°C to 60°C) with 20% to 90% humidity, non-condensing
Operating temperature	41°F to 95°F (5°C to 35°C) with 20% to 80% humidity, non-condensing

SMART order numbers

SP524-NB	SMART Podium 524 interactive pen display with SMART Notebook software.
SP524-MP	SMART Podium 524 interactive pen display with SMART Meeting Pro software and a SMART GoWire™ auto-launch cable with SMART Meeting Pro software.

SPECIFICATIONS

SMART Podium interactive pen display – Models SP524-NB and SP524-MP

Physical dimensions

Side view
(with stand)

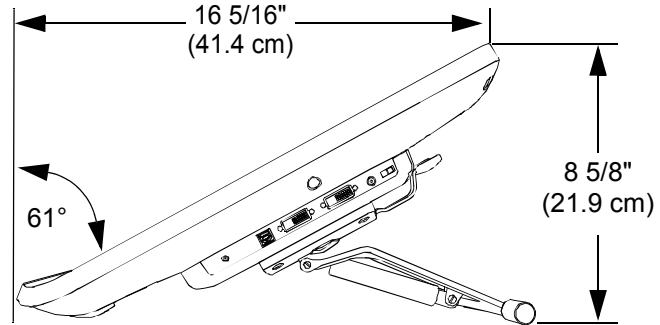
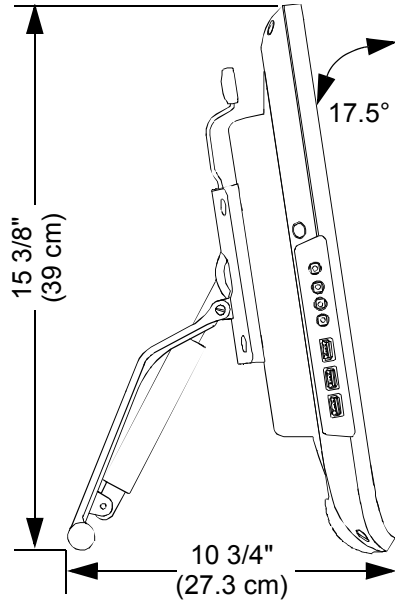

Front view

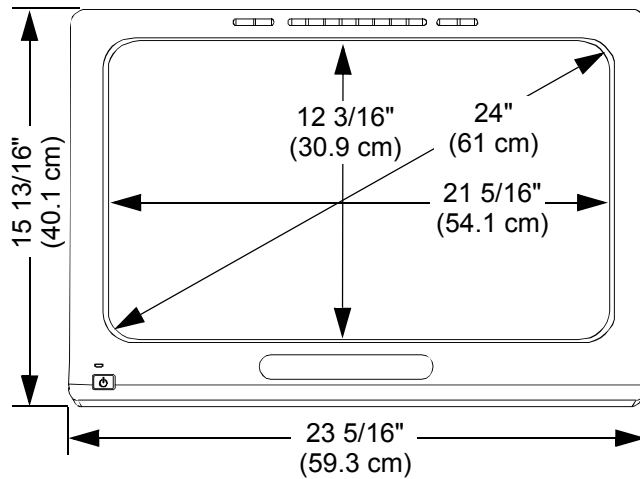

Side view
(without stand)

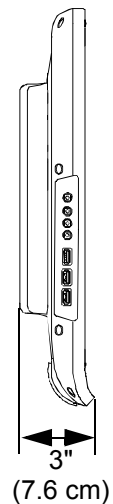

www.smarttech.com/support
www.smarttech.com/contactsupport

SMARTTM

© 2011 SMART Technologies ULC. All rights reserved. SMART Podium, SMART Notebook, SMART Meeting Pro, DVIT, SMART GoWire, smarttech, the SMART logo and all SMART taglines are trademarks or registered trademarks of SMART Technologies ULC in the U.S. and/or other countries. All other third-party product and company names may be trademarks of their respective owners. One or more of the following patents: US6320597; US6326954; US6741267; US7151533; US7757001; US7932899; USD612396; USD616462; USD617332; USD636784; US5317140; US6563491; US6803906; US6919880; US6954197; US7184030; US7236162; US7289113; US7619617; US7692625; CA2386094; EP1297488; EP1739528; ES2279823; ZL0181236.0; DE60124549. Other patents pending. Contents are subject to change without notice. 08/2011.