

SB600i6

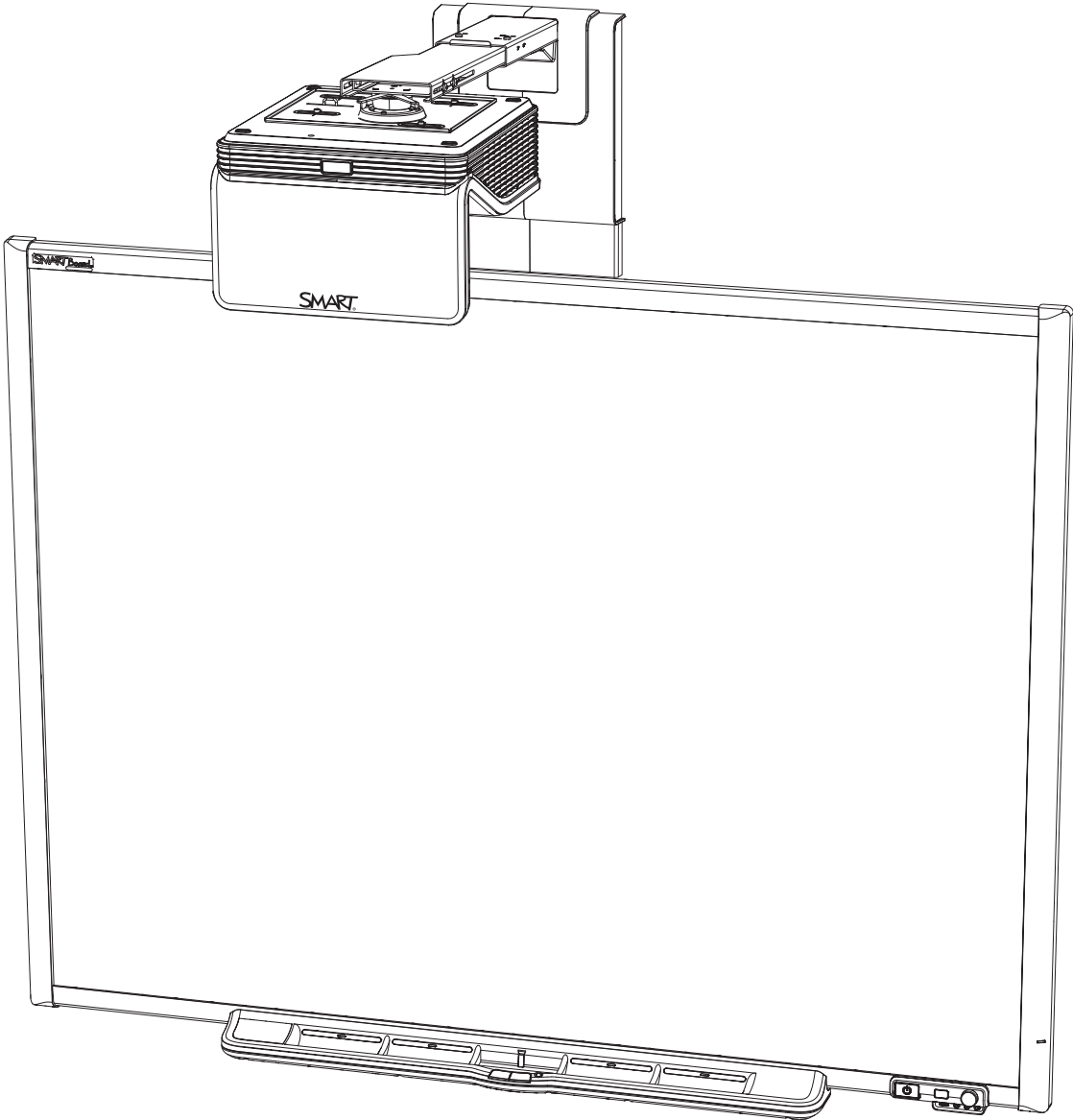

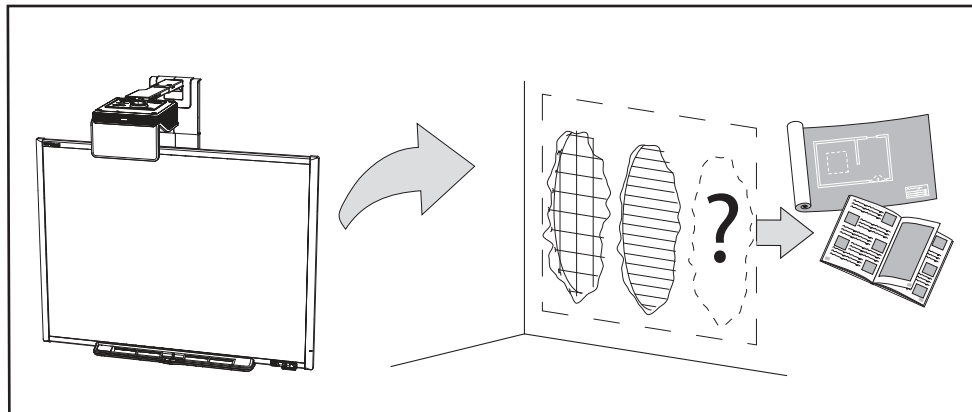

Your SMART product includes instructions for installation on metal and wood stud walls and certain masonry wall types only. In the event that you need to install your SMART product on reinforced concrete walls, walls with plaster lath finishing, walls of unusual construction or other types of walls, refer to your local building authority for instructions, recommendations, and safe work practices.

يتضمن منتج SMART إرشادات للتركيب على الحوائط المعدنية والخشبية وبعض أنواع الحوائط الطوبية فقط. في حالة الحاجة إلى تثبيت منتج SMART على حوائط خرسانية مقواة، أو حوائط ذات طبقة نهائية خشبية وجبسية أو حوائط ذات تراكيب غير معتادة أو أنواع أخرى من الحوائط، راجع هيئة البناء المحلية للتعرف على لتجنب الإصابة أو تلف الممتلكات والمنتجات والذي قد لا يغطيه الضمان، استخدم أجهزة التركيب الموصى بها فقط لجهاز

Váš produkt SMART obsahuje pokyny pro instalaci pouze na hrázděné stěny s kovovými a dřevěnými příčkami a na stěny z určitého druhu zdiva. Pokud potřebujete nainstalovat produkt SMART na stěny ze železobetonu, stěny ze sádkkartonu, stěny neobvyklé konstrukce a jiné druhy stěn, obraťte se na místní stavební úřad, kde vám sdělí příslušné pokyny, doporučení a bezpečné pracovní postupy.

SMART-produkter inkluderer kun instruktioner til installation på vægge med metal- og træstolper samt visse murstensvægge. Rådfør dig med de lokale byggemyndigheder ang. instruktioner, anbefalinger og sikker arbejdspraksis, hvis du er nødt til at installere SMART-produktet på en jernbetonvæg, pudsbelædt væg, en væg af usædvanlig konstruktion eller en anden vægtype.

Im Lieferumfang Ihres SMART-Produkts ist eine Gebrauchsanweisung für die Montage an Metallständer-, an bestimmten Trockenbauwänden sowie bestimmten Ziegelwänden enthalten. Für den Fall, dass Sie Ihr SMART-Produkt an verstärkten Betonwänden, verputzten Wänden, ungewöhnlich gebauten Wänden oder anderen Wandarten montieren müssen, wenden Sie sich an die lokale Baubehörde für nähere Anweisungen, Empfehlungen und sichere Arbeitspraktiken.

Το προϊόν σας SMART περιλαμβάνει οδηγίες για εγκατάσταση σε τοίχους με μεταλλικούς και ξύλινους ορθοστάτες και ορισμένους μόνο τύπους λιθόκτιστων τοίχων. Σε περίπτωση που πρέπει να εγκαταστήσετε το προϊόν σας SMART σε τοίχους από οπλισμένο σκυρόδεμα, τοίχους με φινίρισμα από γυψοσανίδα, τοιχώματα ασυνήθιστης κατασκευής ή άλλους τύπους τοιχωμάτων, ανατρέξτε στην τοπική αρχή κατασκευών για οδηγίες, συστάσεις και ασφαλείς πρακτικές εργασίας.

Su producto SMART solo incluye instrucciones para la instalación en paredes de entramado metálico y de madera, y en determinadas paredes de albañilería. Si necesita instalar su producto SMART en muros de cemento reforzado, paredes con revoque de yeso, paredes de obra no convencional u otros tipos de paredes, consulte a su autoridad local de edificación para obtener instrucciones, recomendaciones y prácticas seguras de trabajo.

SMART-tuotteen toimituksen mukana tulevat ohjeet ja osat on tarkoitettu vain asennuksiin metalli- ja puukoolinkiseiniin sekä tiettyihin muurattuihin seinätyyppisiin. Jos SMART-tuote on asennettava raudoitettuun betoniseinään, rimoitettuun ja rapattuun seinään, rakenteeltaan epätavalliseen tai muunlaiseen seinätyyppiin, pyydä paikalliselta rakennusviranomaiselta ohjeita, suosituksia ja turvallisia työtapoja.

Votre produit SMART inclut des instructions pour l'installer sur des murs à ossature de bois et de métal et sur certains types de murs en maçonnerie. Au cas où vous devriez installer votre produit SMART sur un mur en béton armé, sur un mur de lattes, sur un mur de structure inhabituelle ou un autre type de mur, consultez votre service de l'urbanisme pour qu'il vous fournisse des instructions, des recommandations et vous dise comment travailler en toute sécurité.

Il prodotto SMART contiene le istruzioni per l'installazione su pareti di montanti in legno e metallo e certi tipi di murature in laterizio. Se è necessario installare il prodotto SMART su pareti in cemento armato, pareti con finiture a listello e intonaco, edificate in maniera insolita o di altro tipo, contattare le autorità edilizie locali per istruzioni,



SMART 製品には、金属製および木製スタッドウォール、および特定の種類の石積み壁にのみ対応する設置用の指示書が同梱されています。SMART 製品を鉄筋コンクリートの壁、しっくい木摺り仕上げの壁、独特な構造の壁、あるいは、その他の壁などに取り付ける必要がある場合は、その手順や推奨事項、安全な作業のための事例などについて、地域の建築担当部署へお問合せください。

SMART 제품에는 금속 또는 목재 셋기등벽(stud wall)과 특정 석재 재질의 벽에 부품을 설치하는 것에 대한 지침만 포함되어 있습니다. SMART 제품을 철근 콘크리트벽, 석고보드 마감벽, 특수 공법으로 건축된 벽 또는 기타 유형의 벽에 설치하려는 경우, 해당 지역의 건축 관계 당국에 문의하여 작업 지침과 권장 사항 및 안전한 시공 방법을 확인하십시오.

Uw SMART-product bevat uitsluitend instructies voor montage aan metalen en houten muren of muren met bepaalde soorten metselwerk. Indien u het SMART-product wilt monteren aan muren van gewapend beton, muren met pleisterwerk of muren van een bijzonder type constructie, raadpleeg dan uw plaatselijke bouwautoriteit voor instructies, aanbevelingen en veilige werkwijzes.

SMART-produktet er vedlagt anvisninger for montering kun på støttevegger av metall og tre, samt visse murvegger. I tilfelle du må installere SMART-produktet på armerte betongvegger, gipsvegger, uvanlig bygde vegger eller andre type vegger, kontakt lokale bygningsmyndigheter for å få anvisninger, anbefalinger og råd om trygge fremgangsmåter.

Produkt SMART zawiera tylko instrukcje na temat instalacji na ścianach metalowych i szkieletowych i niektórych typach ścian murowanych. Jeśli musisz zainstalować produkt SMART na ścianach żelbetonowych, ścianach tynkowanych na listwach podtynkowych, ścianach o nietypowej konstrukcji lub innych typach ścian, zwróć się do lokalnego organu nadzoru budowlanego o wskazówki, zalecenia i wytyczne.

Seu produto SMART inclui instruções para instalação em paredes de metal e viga de madeira e somente em determinados tipos de parede de alvenaria. Caso você precise instalar seu produto SMART em parede de concreto reforçado, em paredes com acabamento em placas de argamassa, paredes de construção pouco comuns ou outros tipos de paredes, consulte a autoridade de construção local para obter instruções, recomendações e práticas de trabalho seguras.

O seu produto SMART inclui instruções para instalação em paredes com vigas de metal e de madeira e em determinados tipos de paredes de alvenaria. Se tiver de instalar o seu produto SMART em paredes de betão reforçado, paredes com acabamento de gesso, paredes com construção invulgar ou outros tipos de paredes, consulte a autoridade de construção local para obter instruções, recomendações e práticas de trabalho seguras.

В комплект продукта SMART входят инструкции, необходимые для монтажа продукта на металлические или деревянные каркасные стены и на кирпичные стены определенного типа. В случае необходимости монтажа продукта SMART на железобетонные стены, стены со штукатурной отделкой, стены с необычной конструкцией или на стены другого типа, обратитесь в местные компетентные строительные органы за инструкциями, рекомендациями и способами безопасной работы.

Din SMART-produkt inkluderar endast de anvisningar som krävs för installation på väggar med regler av metall eller trä samt på vissa typer av murväggar. Om du behöver installera din SMART-produkt på väggar av armerad betong, putsade väggar, väggar med ovanlig konstruktion eller andra typer av väggar ska du rådfråga den lokala byggnadsnämnden för att få anvisningar, rekommendationer och information om säker arbetsmetod.

SMART 产品附带的说明仅适用于在有金属和木质立柱的墙面上以及某些砖石类型墙面上进行的安装。如果您需要安装 SMART 产品至钢筋混凝土墙面、灰泥板条铺墙面、特殊建材墙面或其他种类墙面时，请咨询当地建筑主管机构获取指示、建议以及安全施工方法。

您的 SMART 產品所附帶的安裝指示僅適用於金屬牆柱牆面、木頭牆柱牆面和特定石材牆面。如您需安裝 SMART 產品至鋼筋混凝土牆、灰泥板條鋪面牆、特殊建材牆面或其他種類牆面時，請洽詢當地建築相關機關尋求指示及建議，以確保施工安全。

SB680/SB685

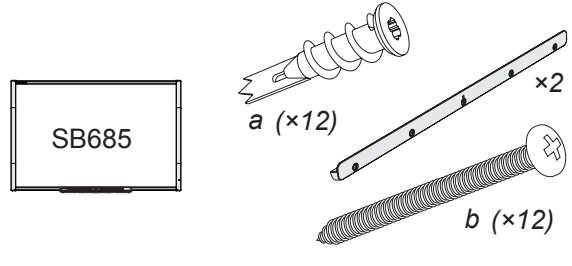
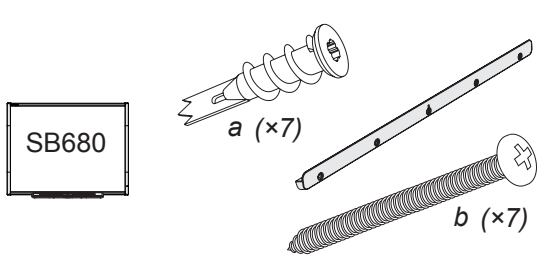
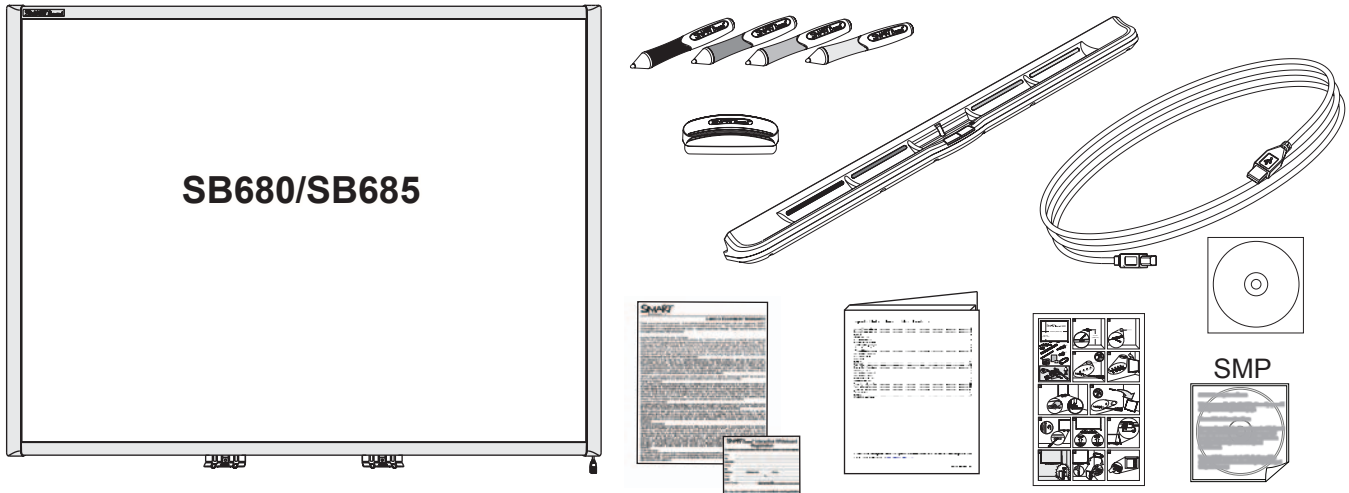

ECP

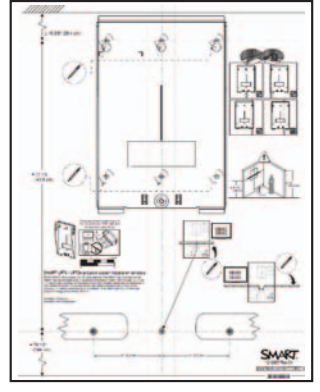
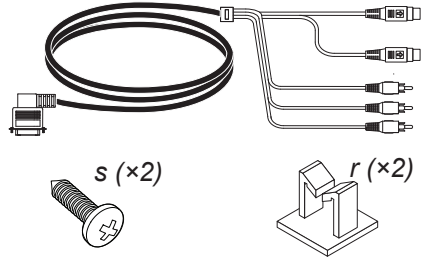
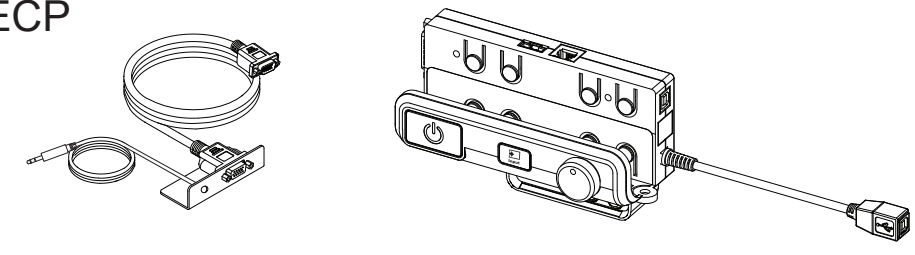

UF70/UF70w

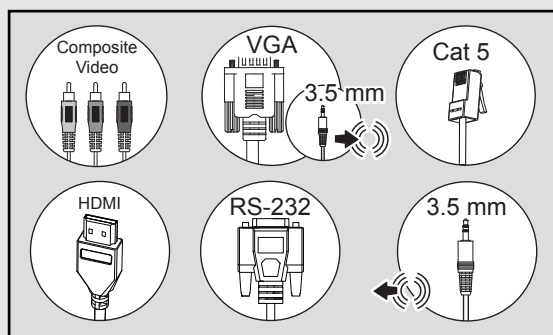
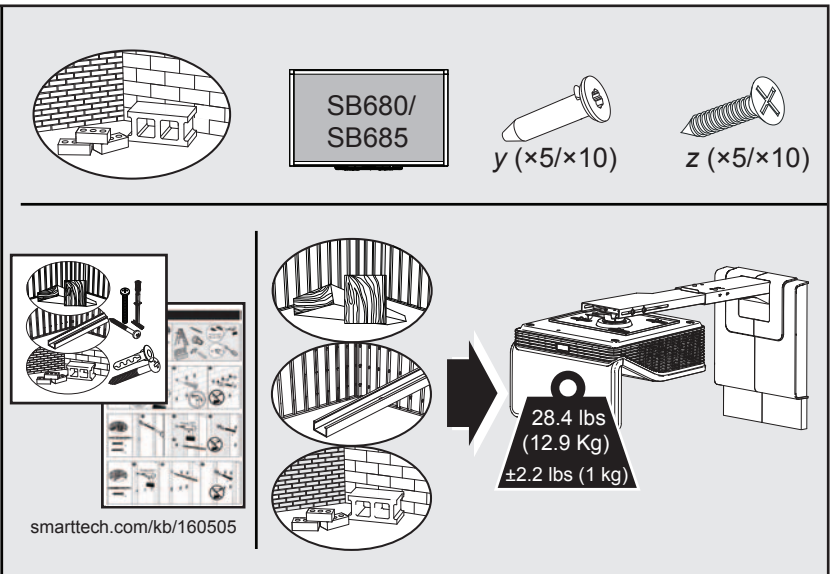
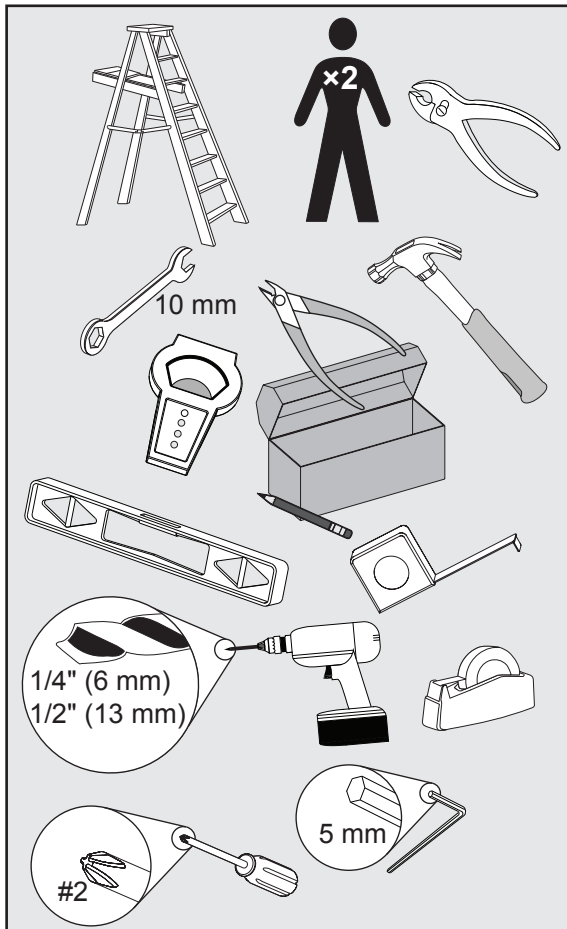
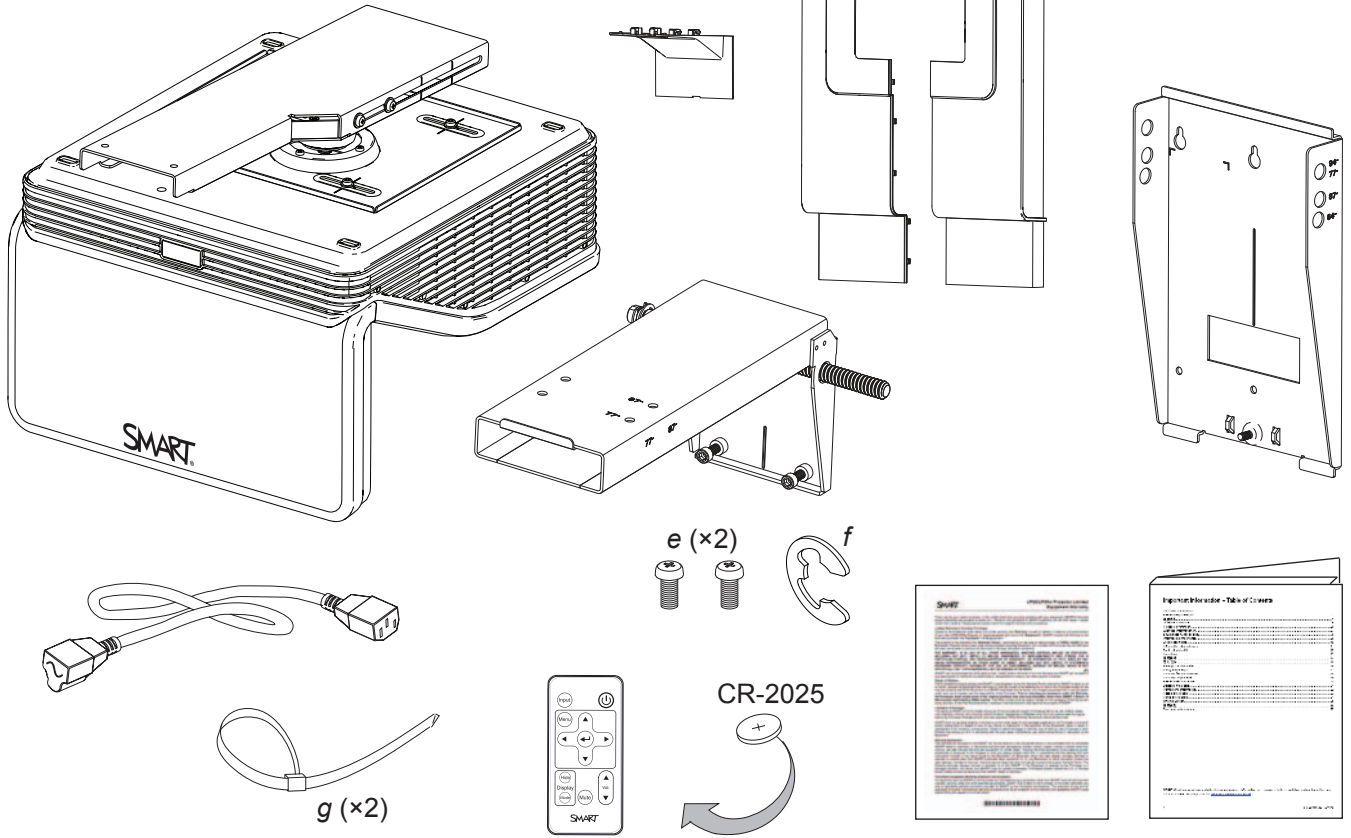

1

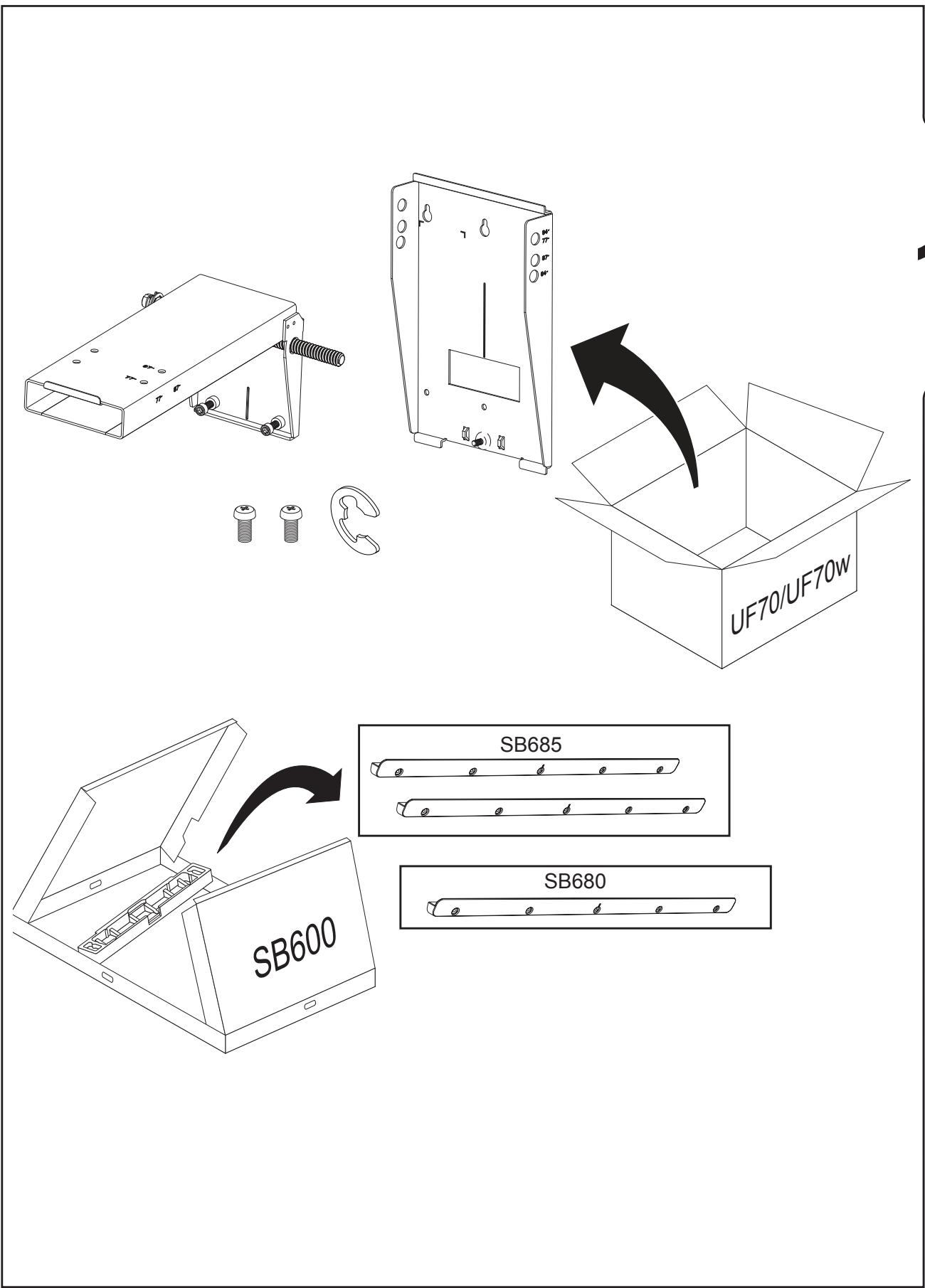

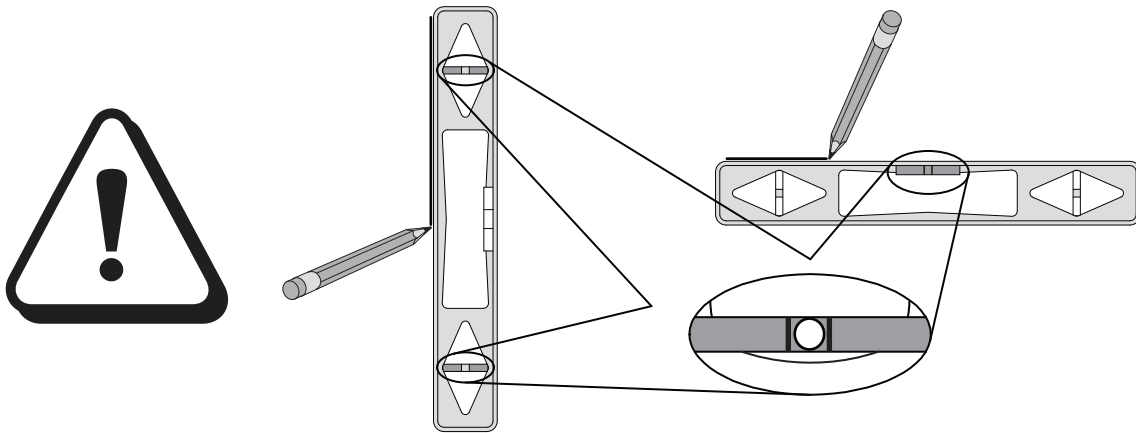

All of the lines that you draw to install the SB600i6 must be straight and level on a plumb wall. You must install the unit straight, level and plumb for it to operate properly.

يجب أن تكون جميع الخطوط التي ترسمها لتركيب SB600i6 مستقيمة ومستوية على حائط رأسي. يجب تركيب الوحدة بشكل مستقيم، ومستوي وعمودي لكي تعمل بشكل صحيح.

Všechny čáry, které při instalaci nakreslíte, musí být rovné a v rovnováze na svislé stěně SB600i6. Jednotku musíte nainstalovat vodorovně a svisle, aby správně fungovala.

Alle de streger, som du tegner, for at installere SB600i6, skal være lige og vandrette på en væg, der er i lod. Du skal installere enheden lige, vandret og i lod for at den vil fungere korrekt.

Sämtliche Linien, die Sie zur Montage des SB600i6 anzeichnen, müssen gerade und eben auf einer lotrechten Wand verlaufen. Das Gerät muss gerade, eben und lotrecht angebracht sein, um ordnungsgemäß zu funktionieren.

Όλες οι γραμμές που σχεδιάζετε για να εγκαταστήσετε το SB600i6 πρέπει να είναι ευθείες και επίπεδες σε κατακόρυφο τοίχο. Πρέπει να εγκαταστήσετε τη μονάδα ευθεία, επίπεδα και κατακόρυφα για να λειτουργεί σωστά.

Todas las líneas que dibuje para instalar el SB600i6 deben ser rectas y niveladas, y en una pared vertical. Para que la unidad funcione correctamente, debe instalarse recta, nivelada y vertical.

Las líneas que trace para instalar la pizarra SB600i6 deben estar bien derechas y a nivel respecto de la pared. Para que la unidad funcione correctamente, también se la deberá instalar bien derecha y a nivel.

Kaikki viivat, jotka vedät SB600i6:n asentamiseksi on oltava suoria ja vaakasuorassa pystysuorassa seinässä. Laite on oikean toiminnan varmistamiseksi kiinnitettävä suoraan, vaakatasoon ja pystysuoraan.

Toutes les lignes que vous tracez pour installer le SB600i6 doivent être droites et horizontales sur un mur vertical. Vous devez installer l'unité bien droite et d'aplomb pour qu'elle fonctionne correctement.

Tutte le linee tracciate per installare l'SB600i6 devono essere dritte e in pari e disegnate su una parete a piombo. Installare l'unità in posizione dritta, in pari e perpendicolare, per assicurarne il funzionamento corretto.

コンクリートのカウンタウエイトが枠の金属部分あるいは壁面に擦れる場合は、SB600i6 全体あるいは一部分が水平ではありません。垂直・水平に正しく取り付けなおしてください。

SB600i6 의 설치를 위해 그리는 모든 선은 직선이고 셋기둥벽에 수평이어야 합니다. 유닛 을 설치할 때는 높이를 맞추고 수직으로 설치해야 정상적으로 작동할 수 있습니다 .

Alle linjene du tegner for å installere SB600i6 må være rette og plane på en loddrett vegg. Du må installere enheten plant og loddrett for at det skal fungere.

Alle lijnen die u trekt als hulp voor de montage van de SB600i6 moeten recht, verticaal waterpas en loodrecht op muur staan. De unit werkt alleen naar behoren als deze recht, verticaal waterpas en loodrecht op de muur is gemonteerd.

Wszelkie linie kreślone w celu instalacji SB600i6 muszą być proste i wy poziomowane na pionowej ścianie. Aby urządzenie działało prawidłowo, należy instalować je prosto, w sposób wy poziomowany i wypionowany.

Todas as linhas que você desenhar para instalar o SB600i6 deverão ser retas e estar niveladas em uma parede vertical. Você deve instalar a unidade reta, nivelada e vertical para que ela funcione apropriadamente.

Todas as linhas que desenhar para instalar o SB600i6 deverão ser rectas e niveladas numa parede a prumo. Para que a unidade funcione correctamente, deverá ser instalada direita, nivelada e a prumo.

Все линии, проводимые для монтажа SB600i6, должны быть прямыми и выровненными вертикально по отвесу. Для корректной работы продукт необходимо устанавливать по прямой линии, на одном уровне и строго вертикально.

Alla linjer som du ritar för montering av SB600i6 måste vara helt våg- och lodräta på väggen. Du måste montera enheten helt våg- och lodrätt för att den ska fungera på rätt sätt.

所有安装 SB600i6 时所画的线在垂直墙面上都必须是笔直和水平的。本装置需直立、水平及垂直地安装才能正常运转。

所有安裝 SB600i6 時所畫的線在垂直牆面上都必須是筆直和水平的。本裝置需直立、水平及垂直的安裝才能正常運轉。

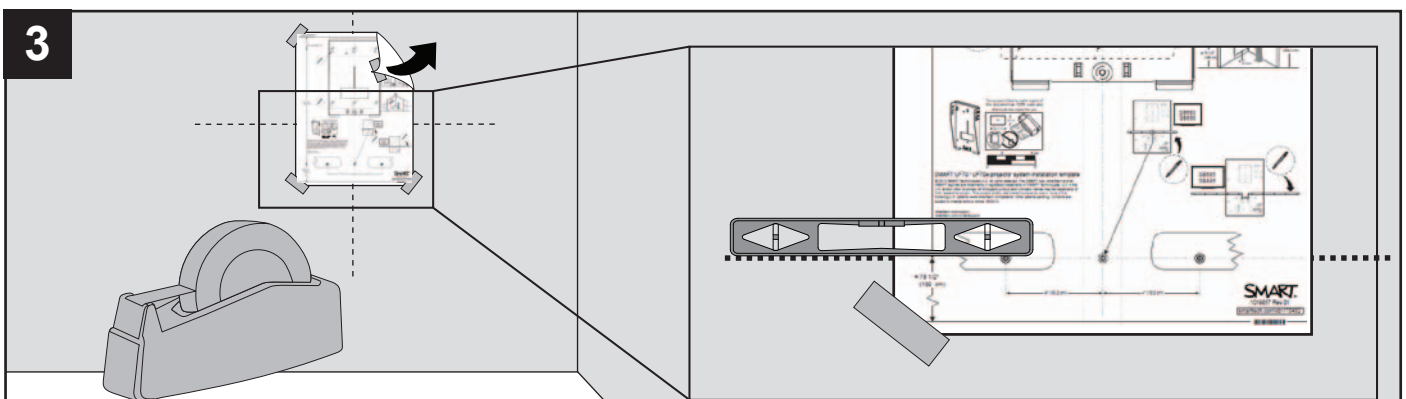
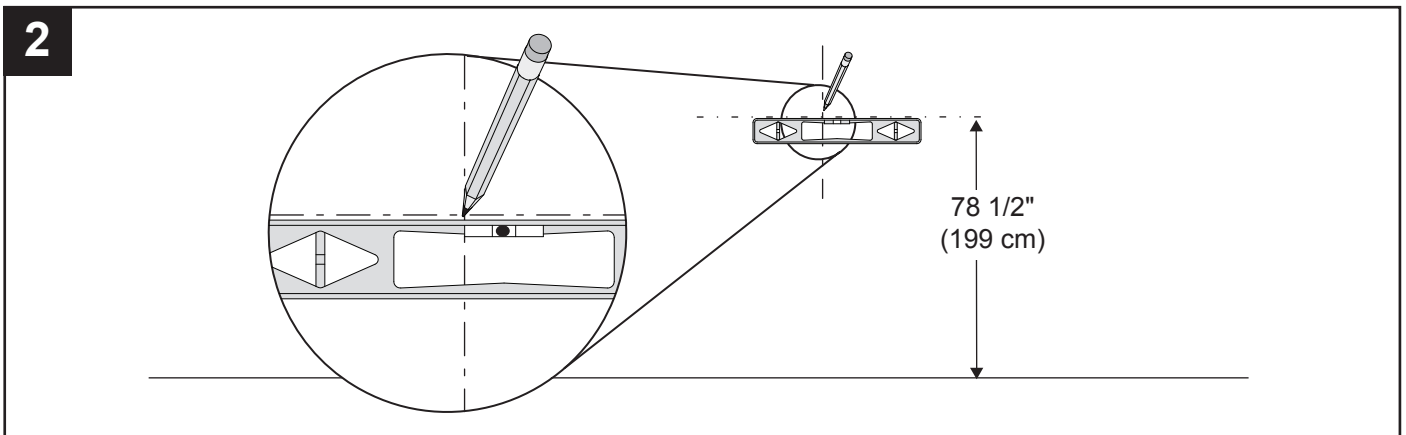
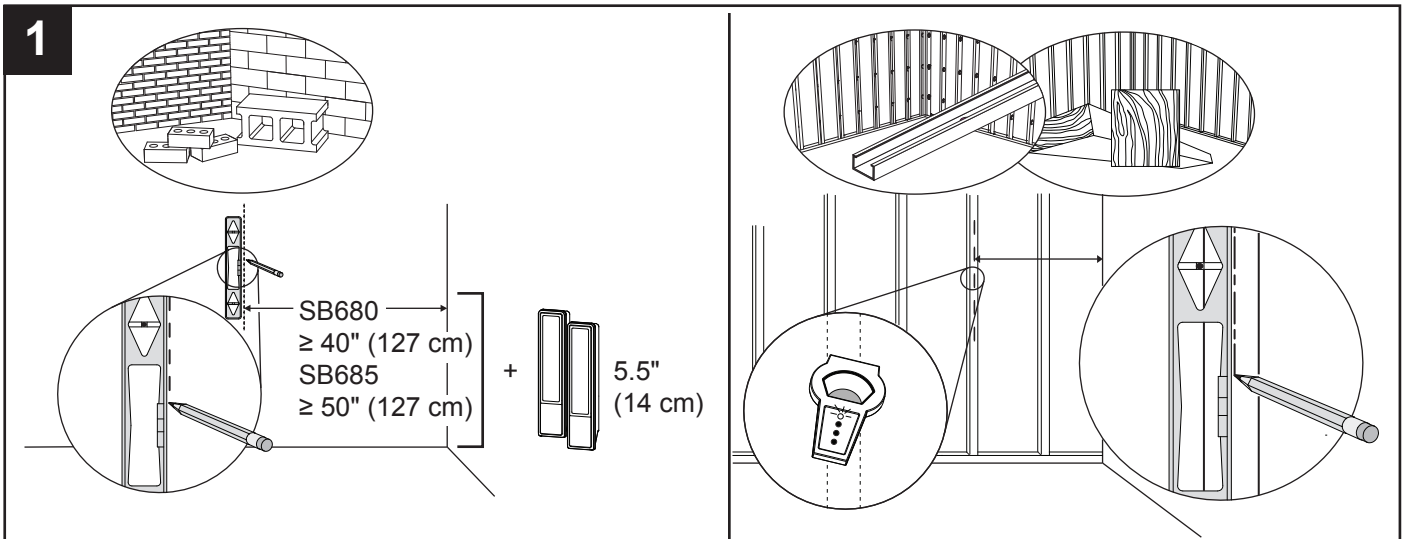

4

A

SB680

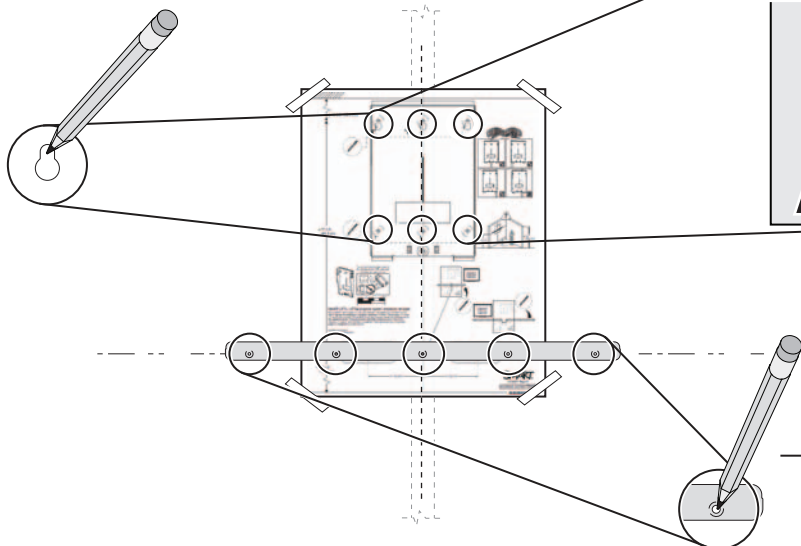
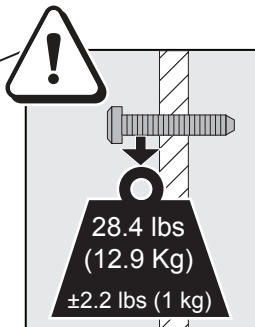

SB685

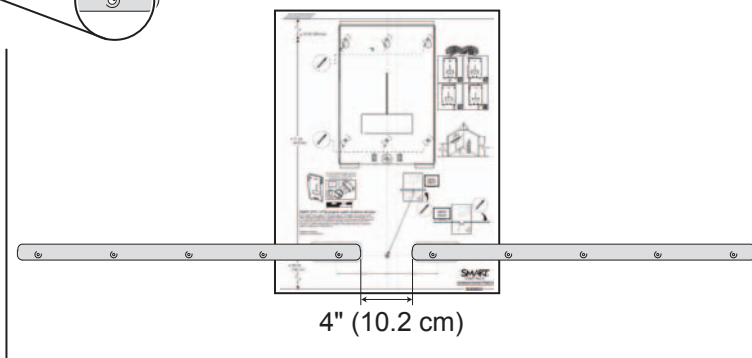

B

1/4" (6 mm)

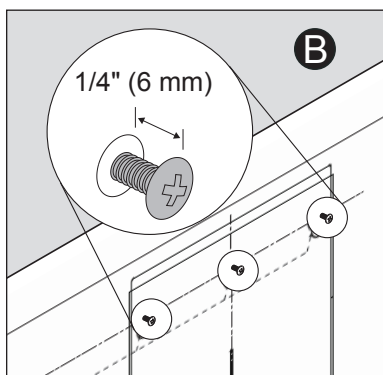

5

A

B

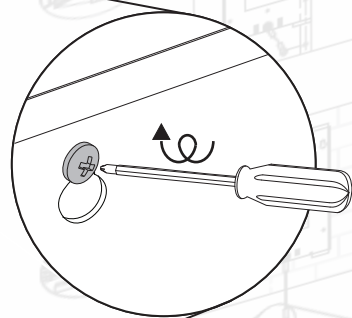

6

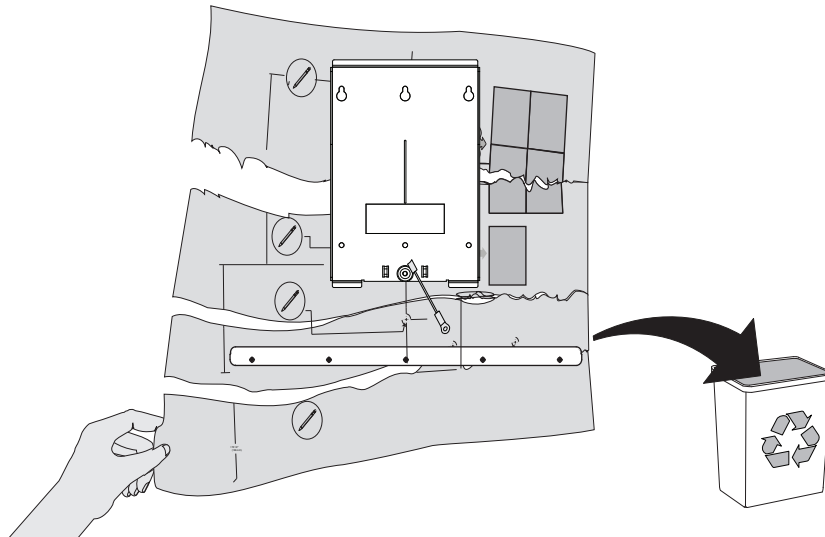
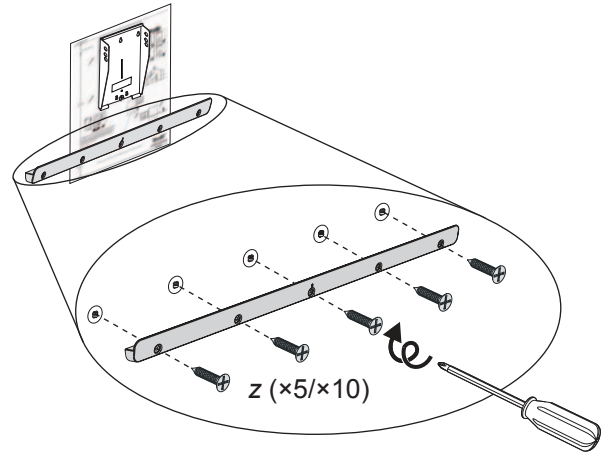
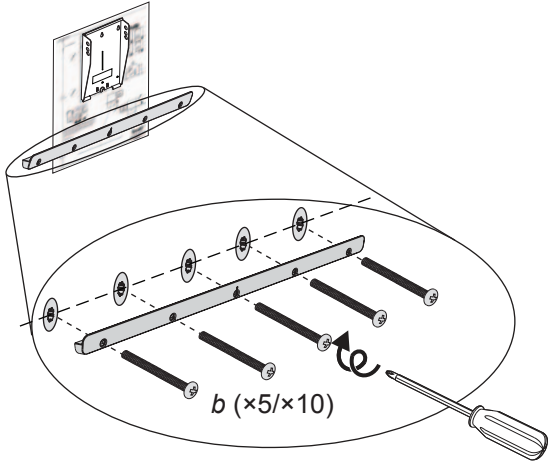
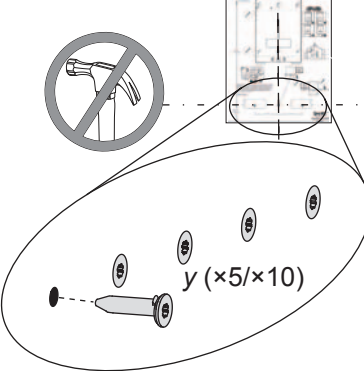
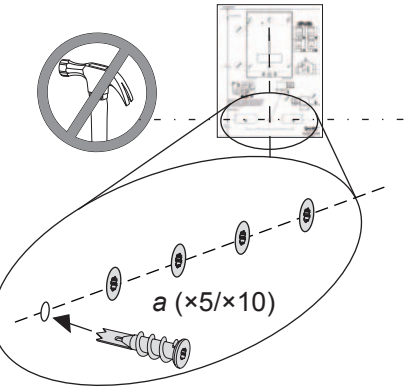
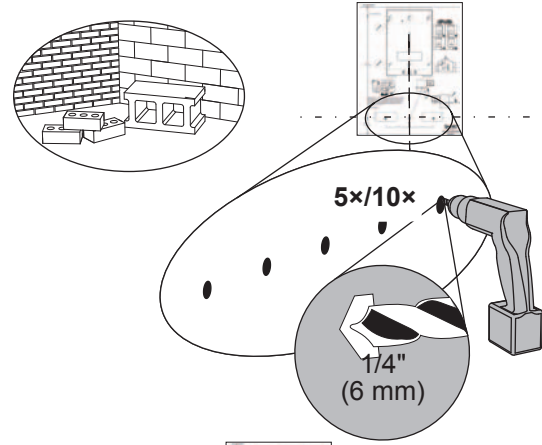
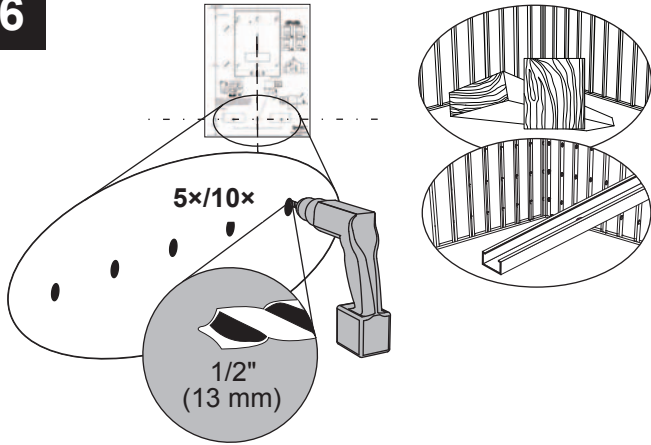

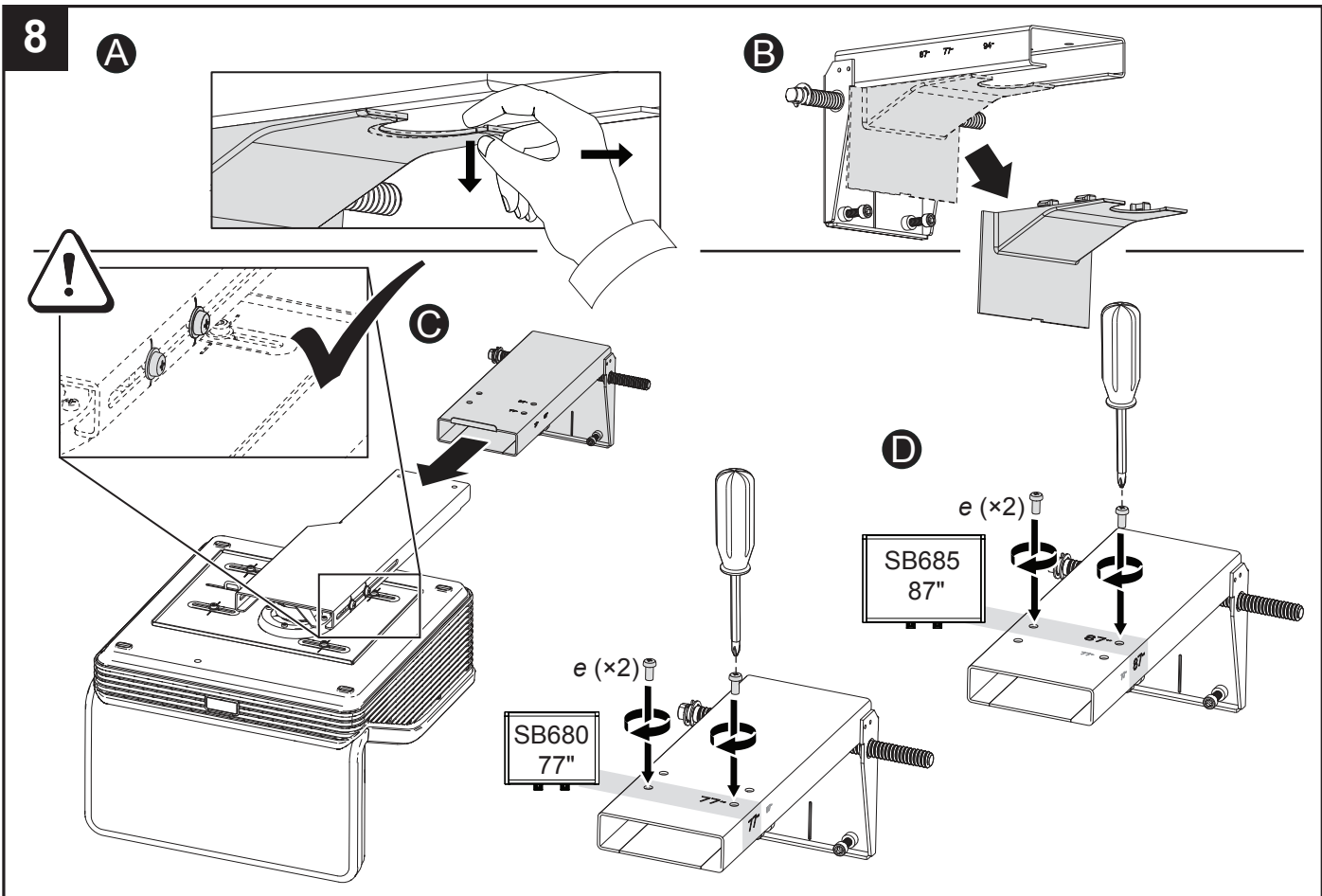
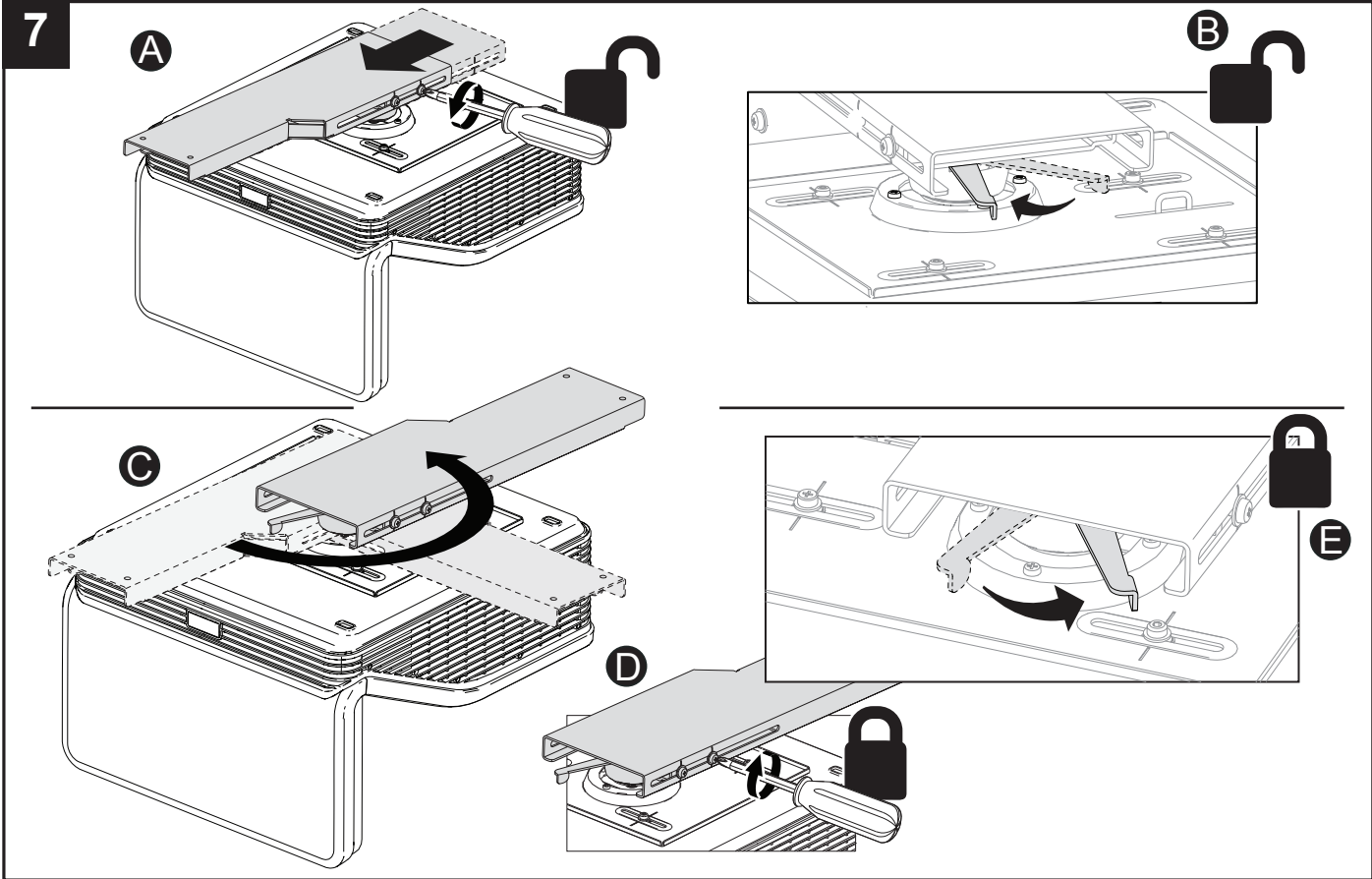

8

A

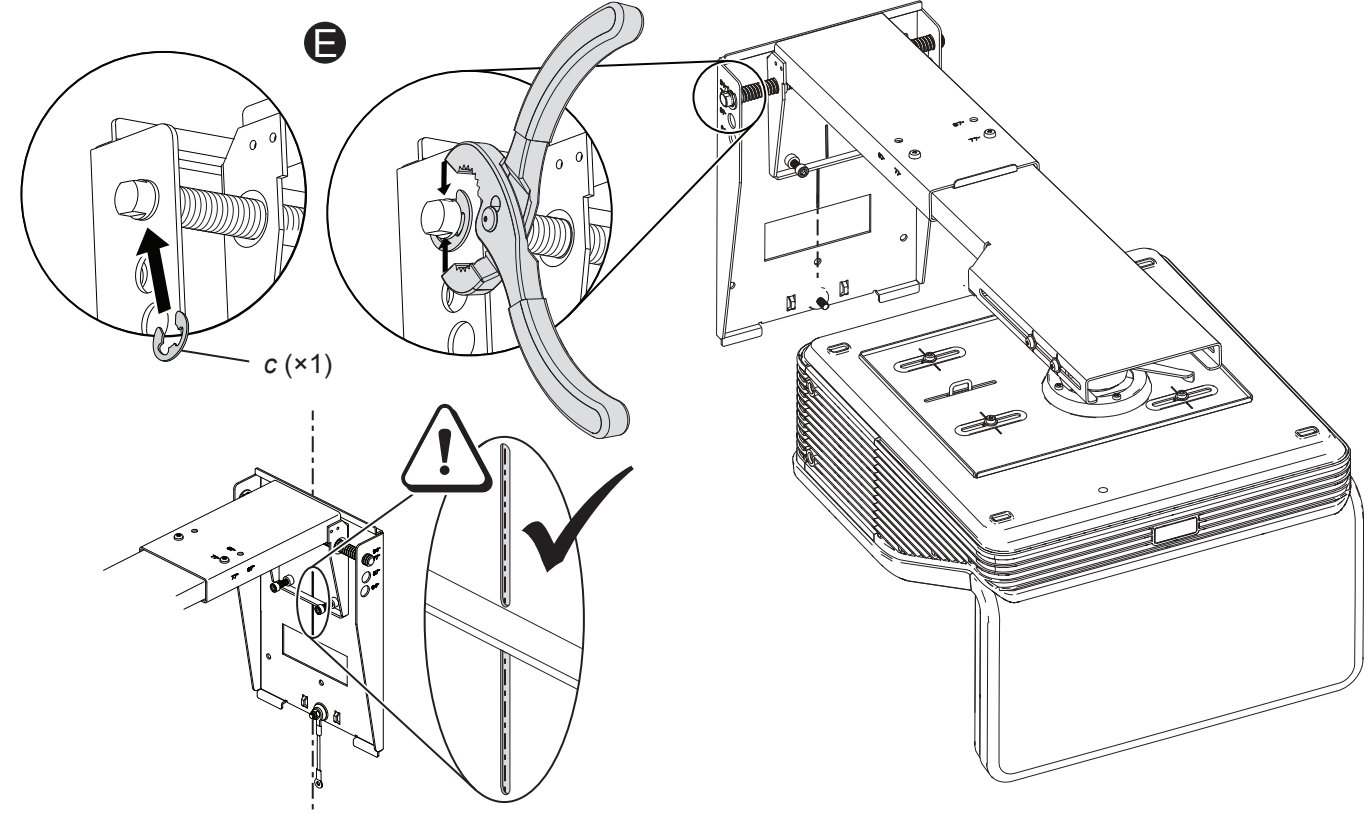
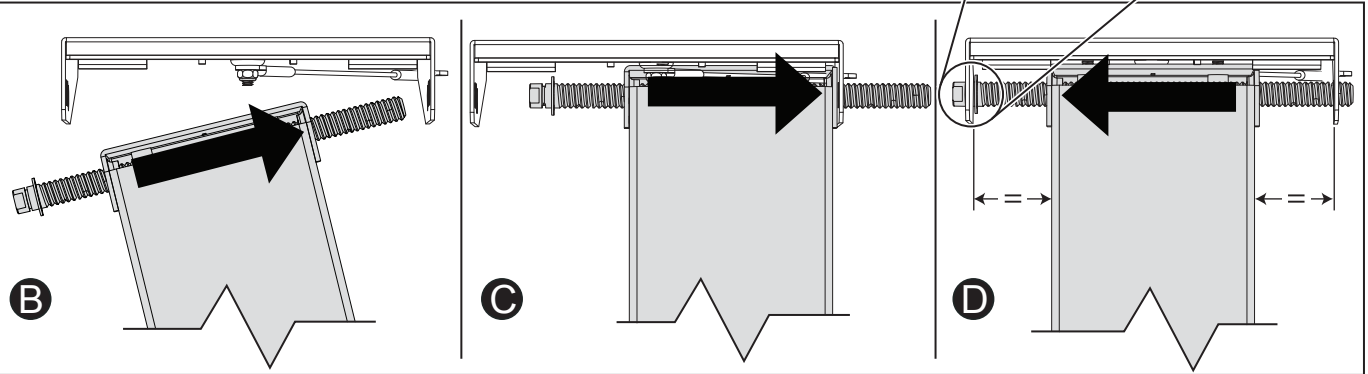
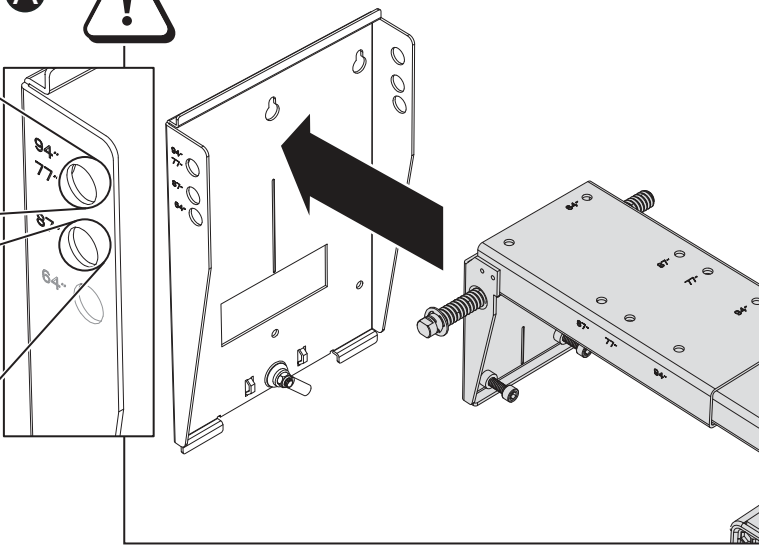
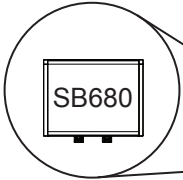



SMART®

2

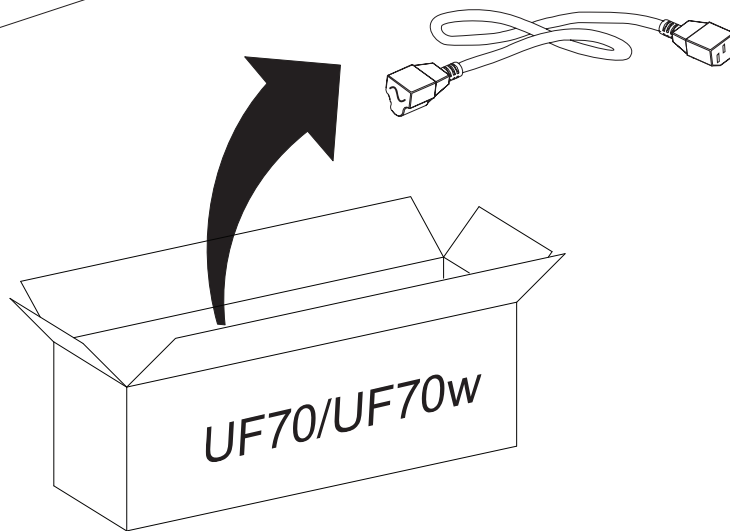
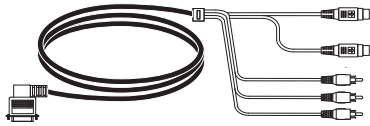
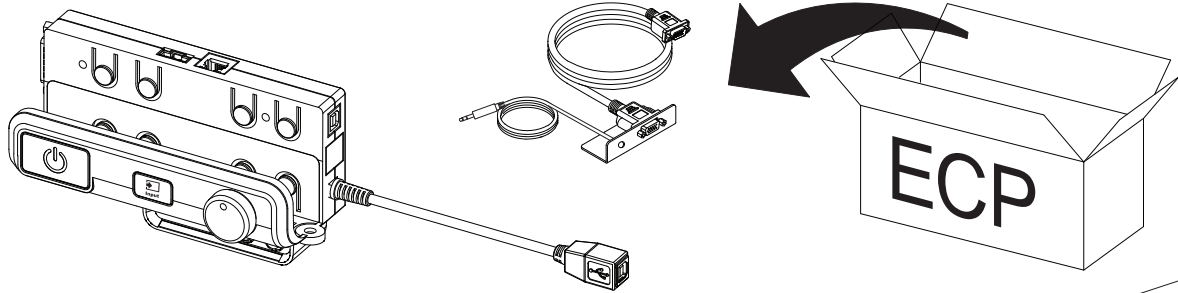

1

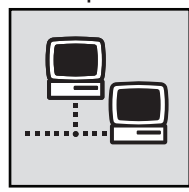
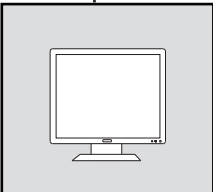
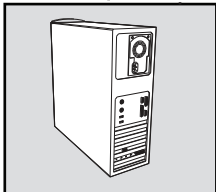
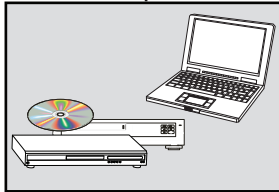
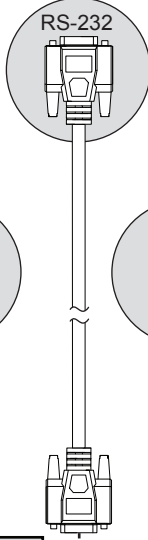
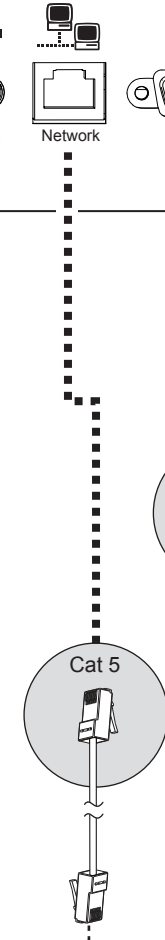
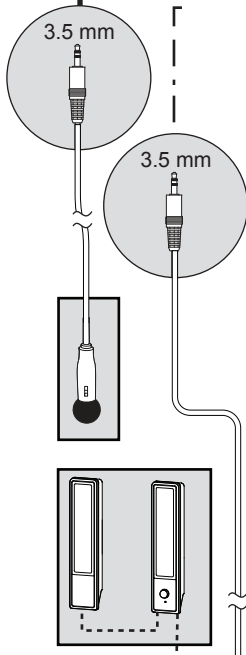
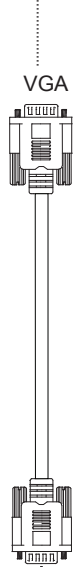
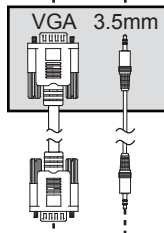
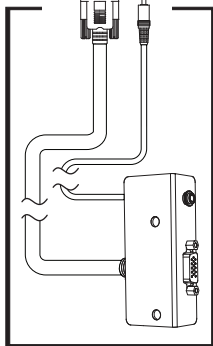
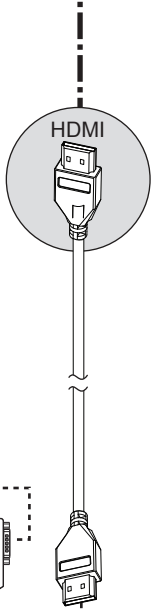
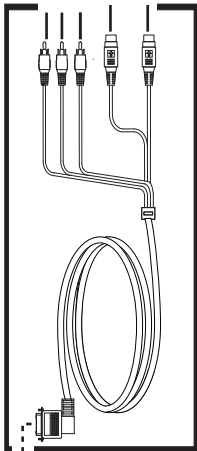
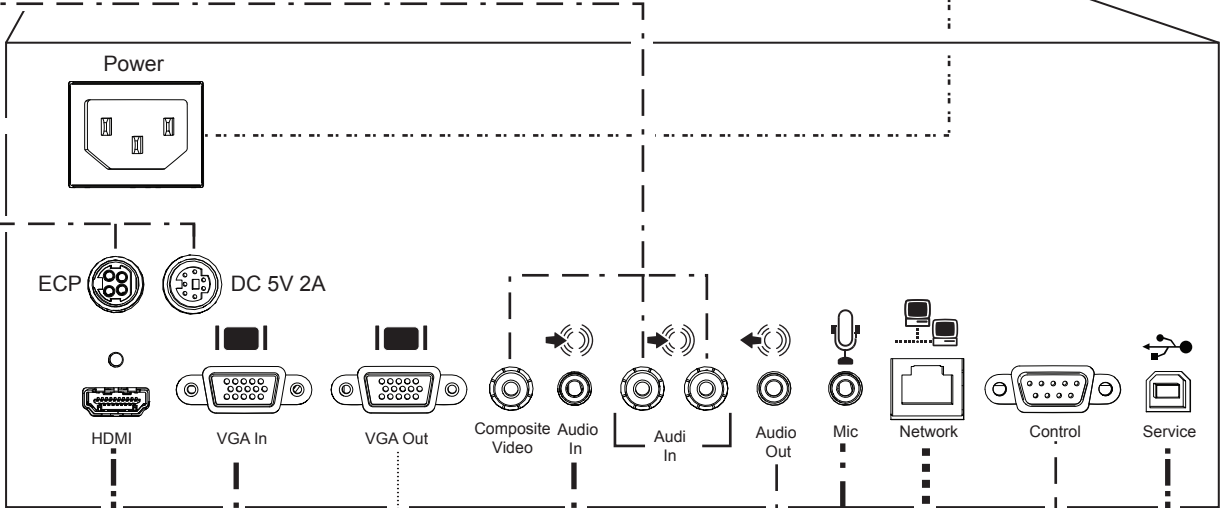
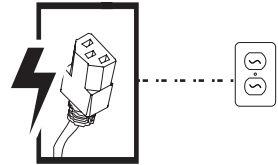
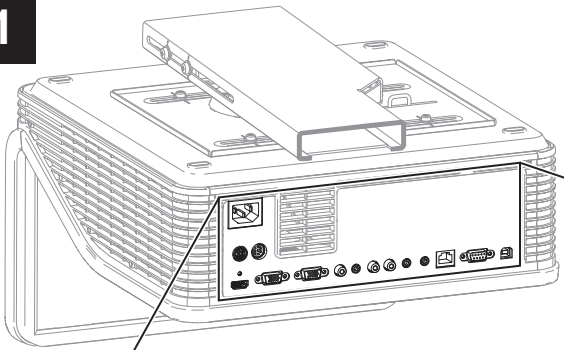

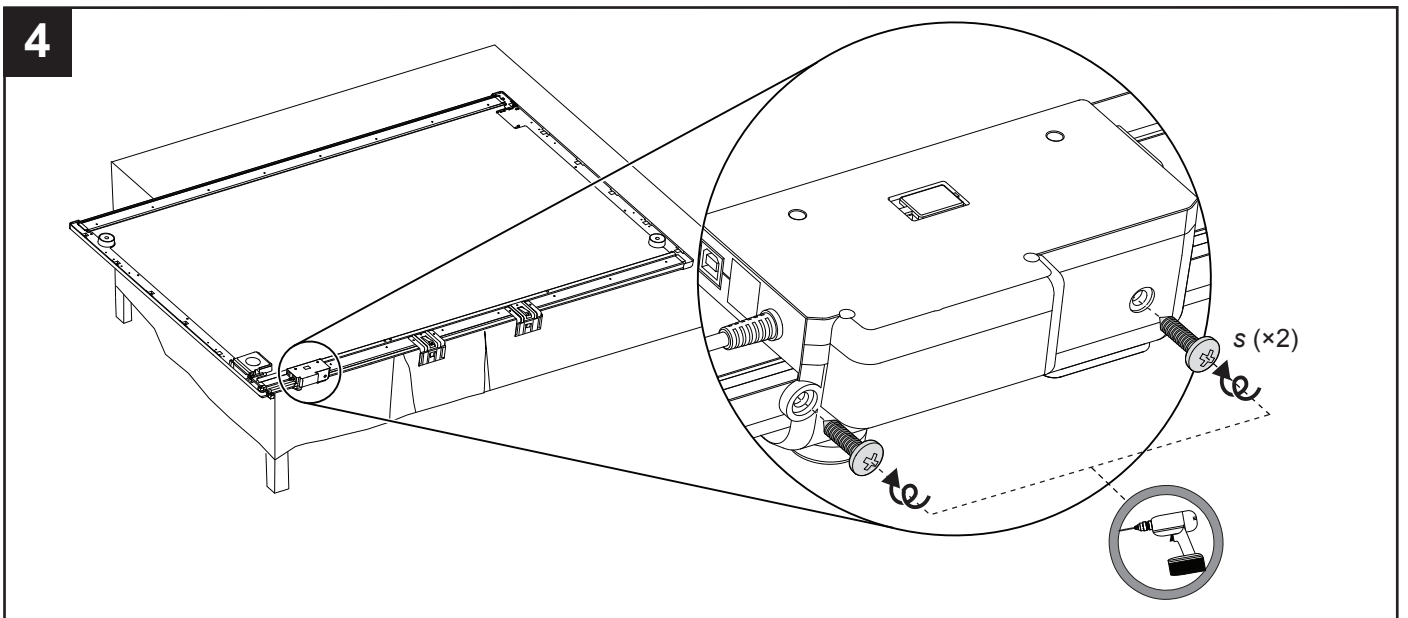
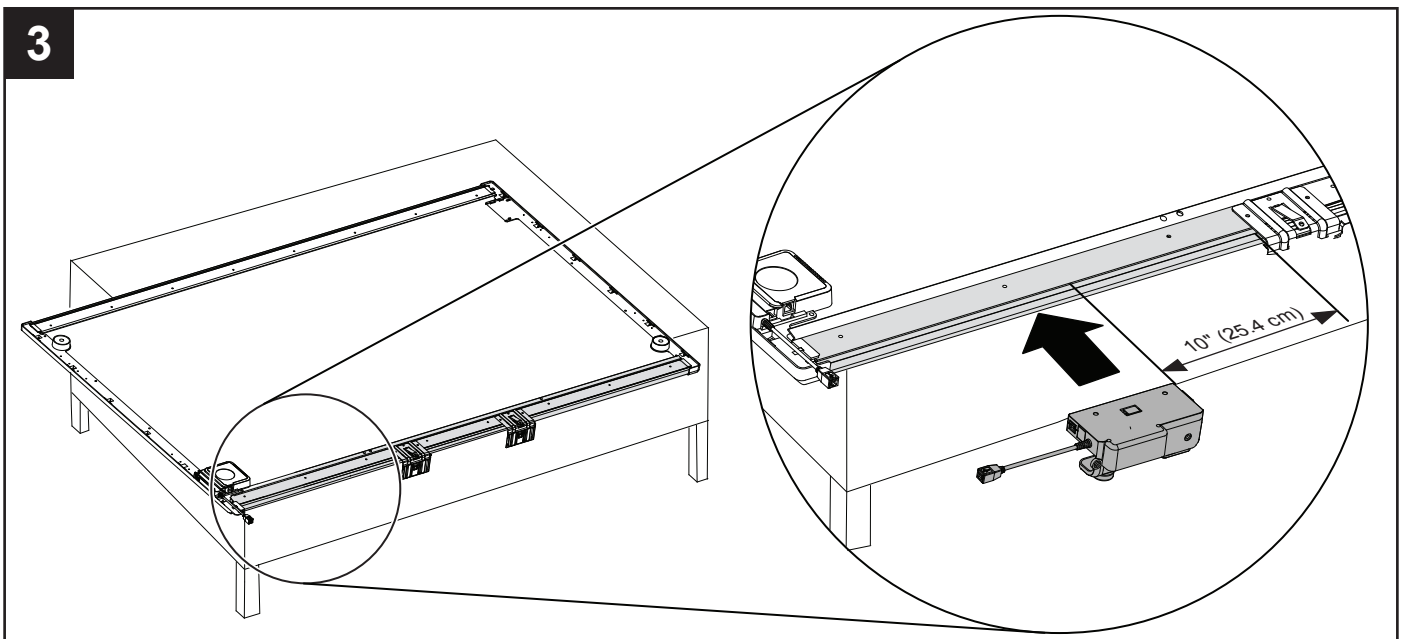
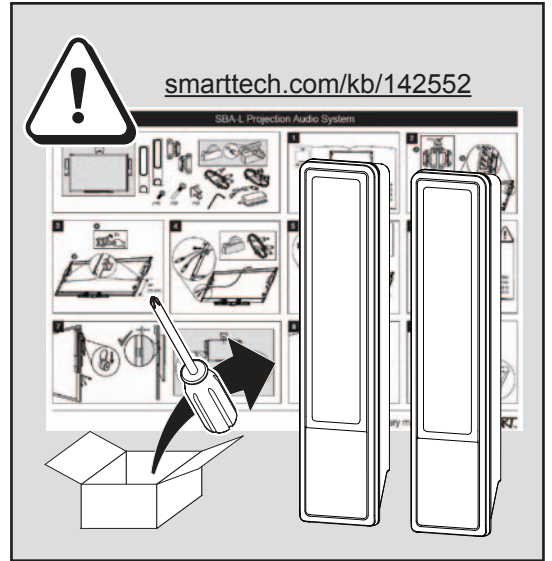
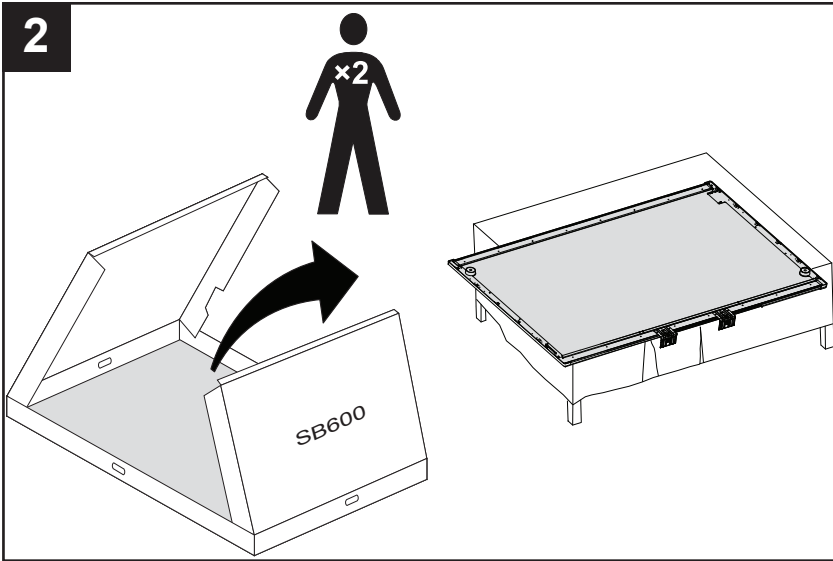

5

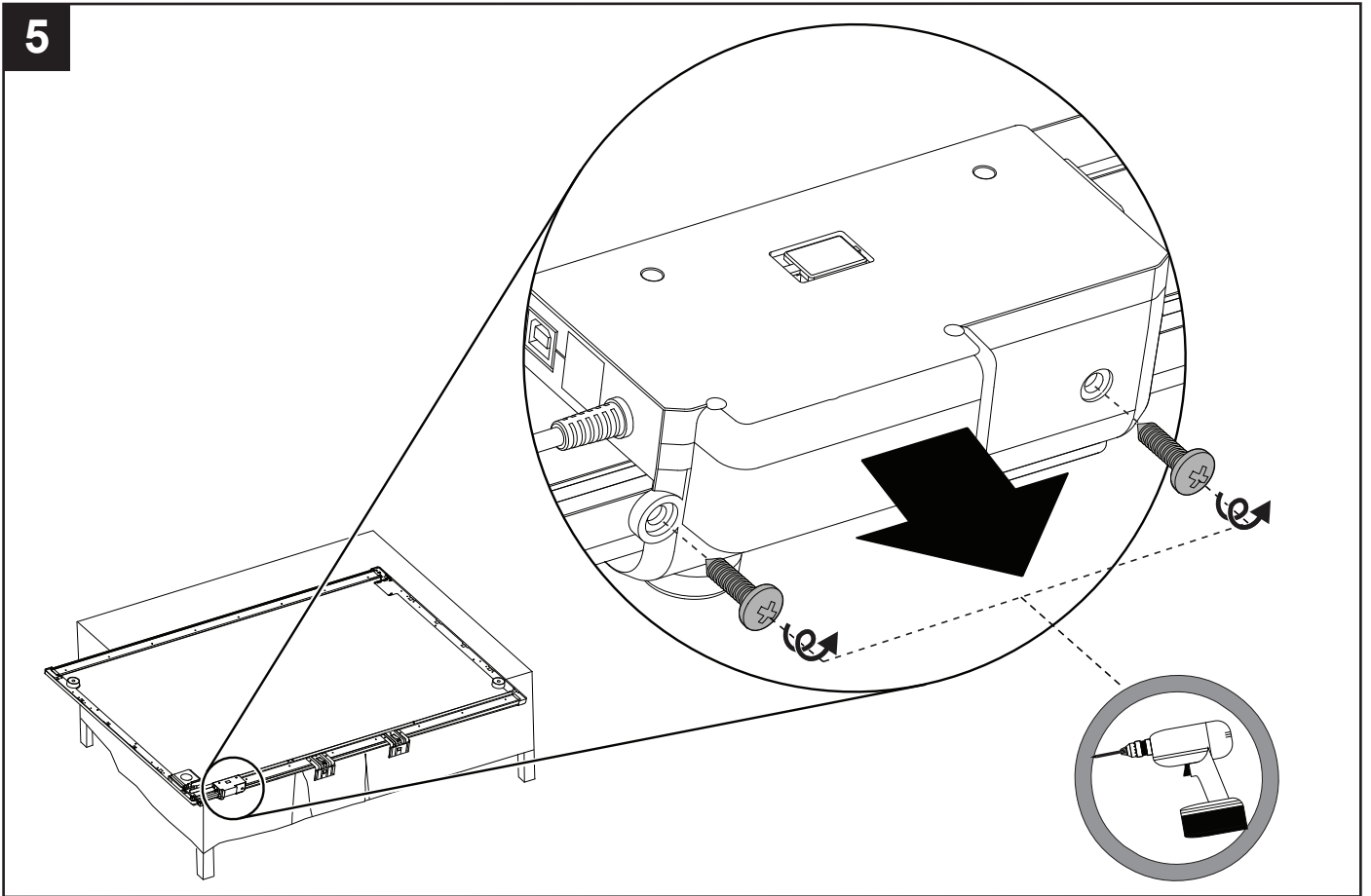

6

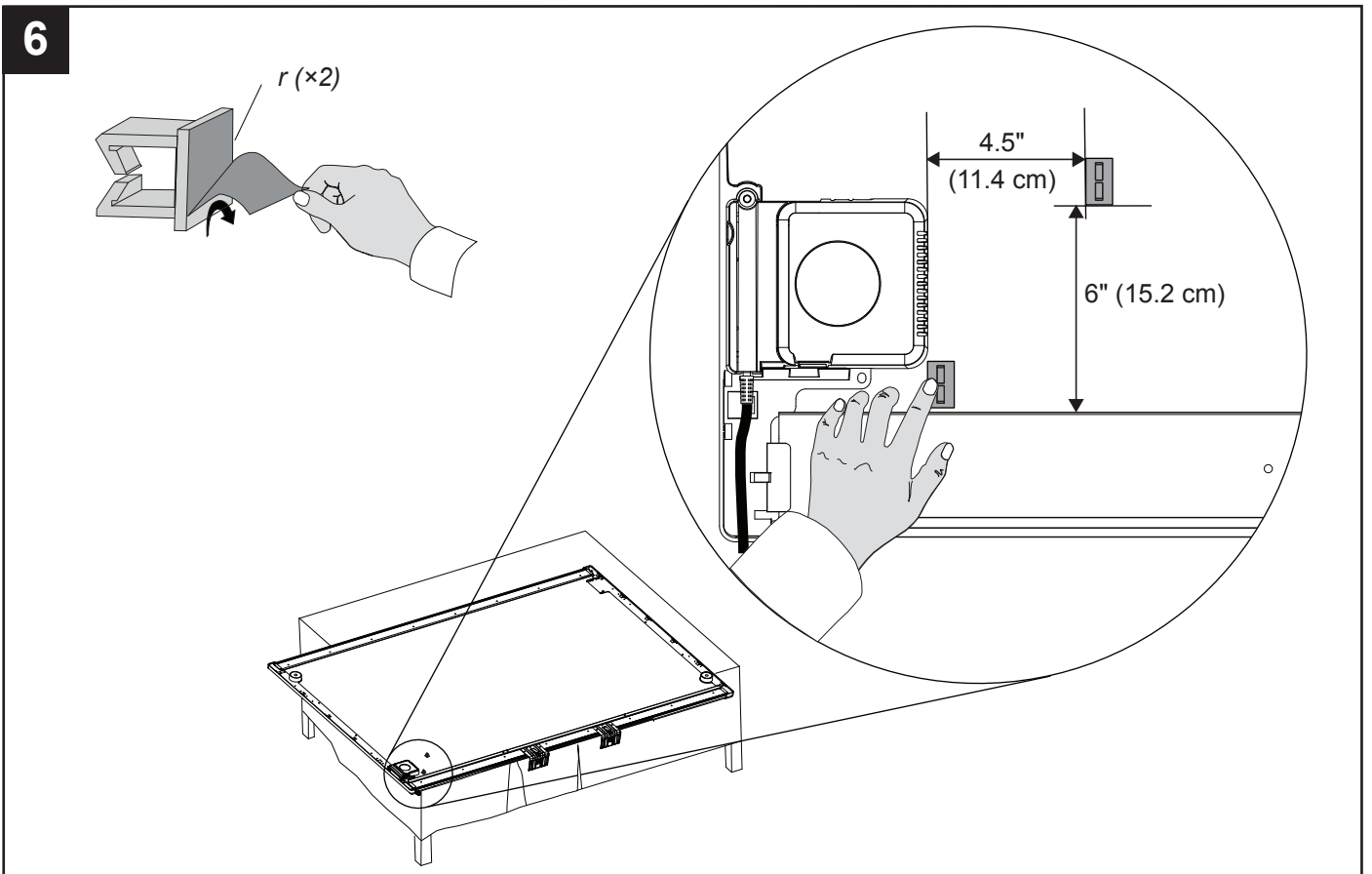

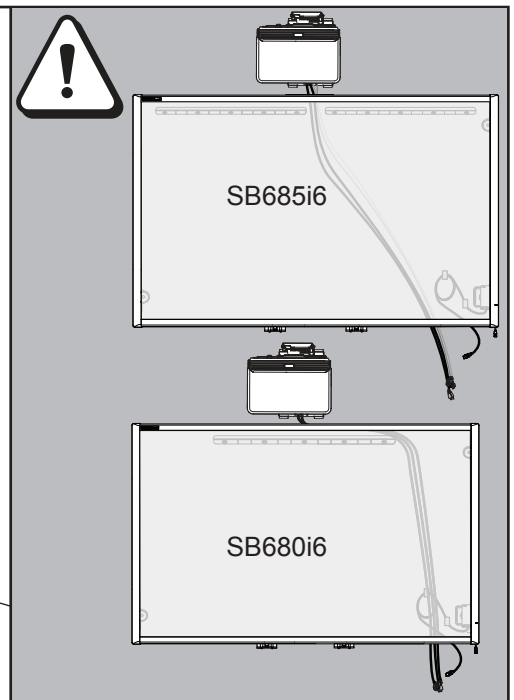
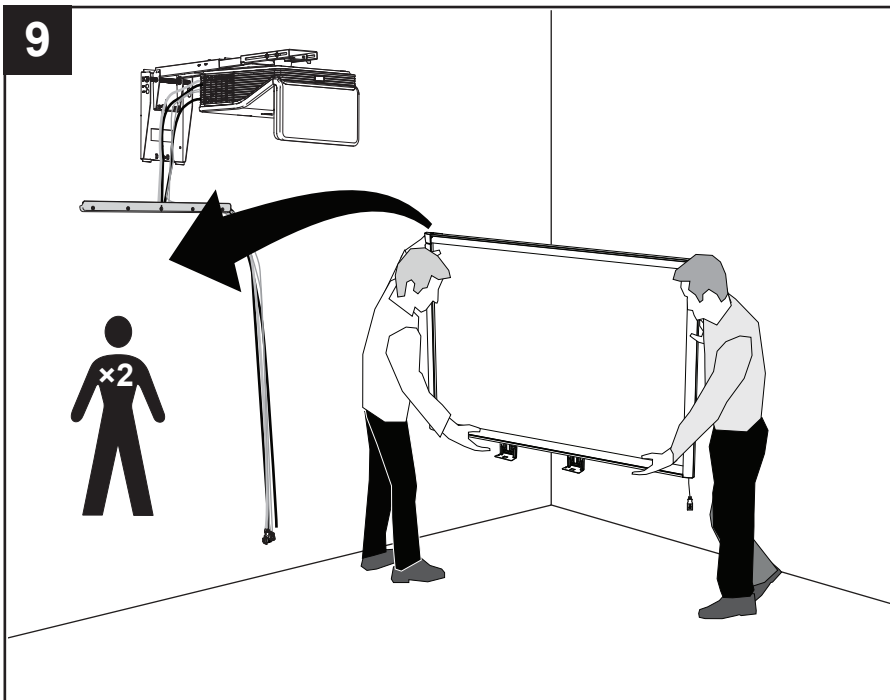
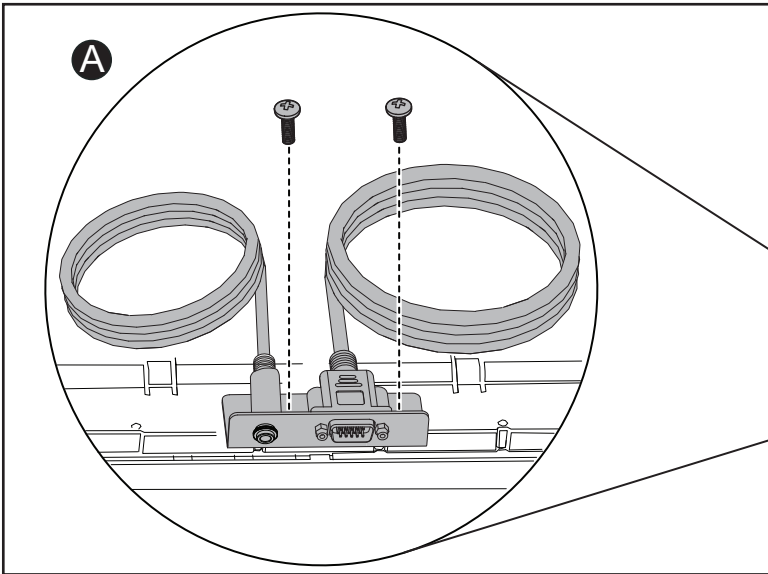
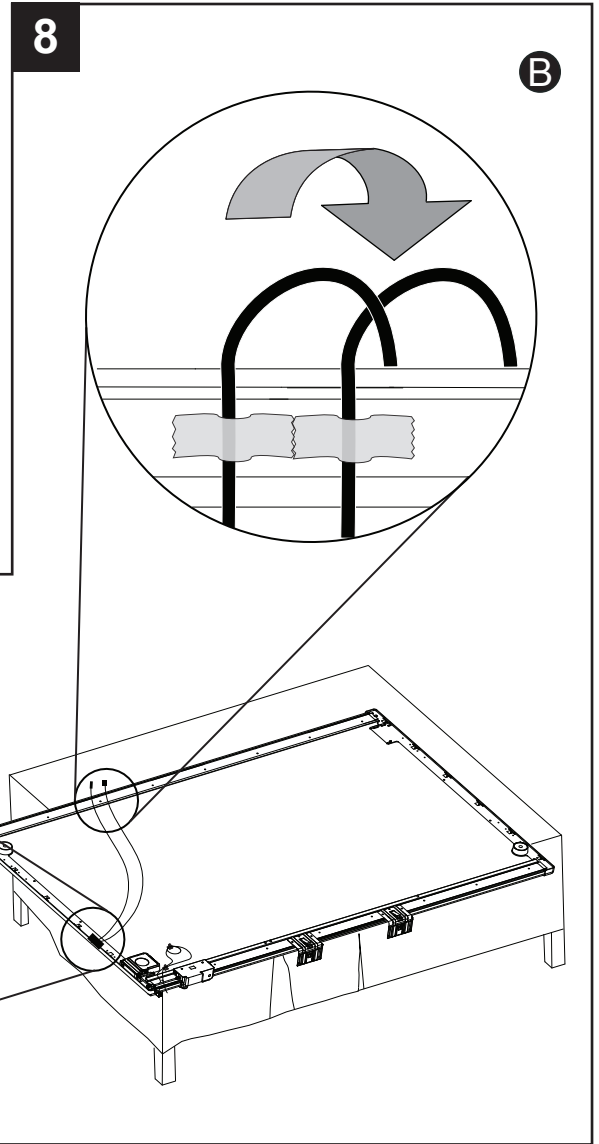
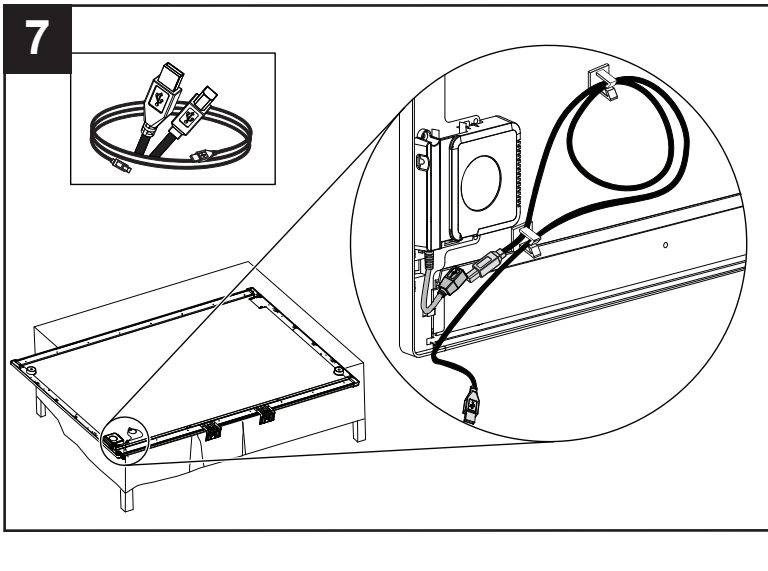

10

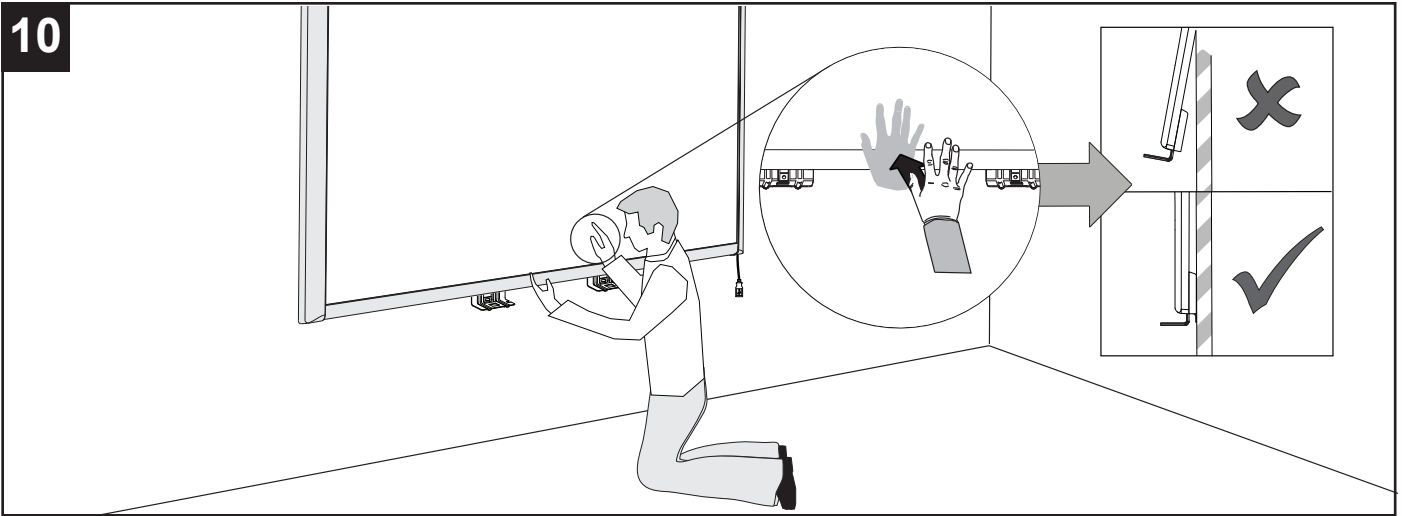

11

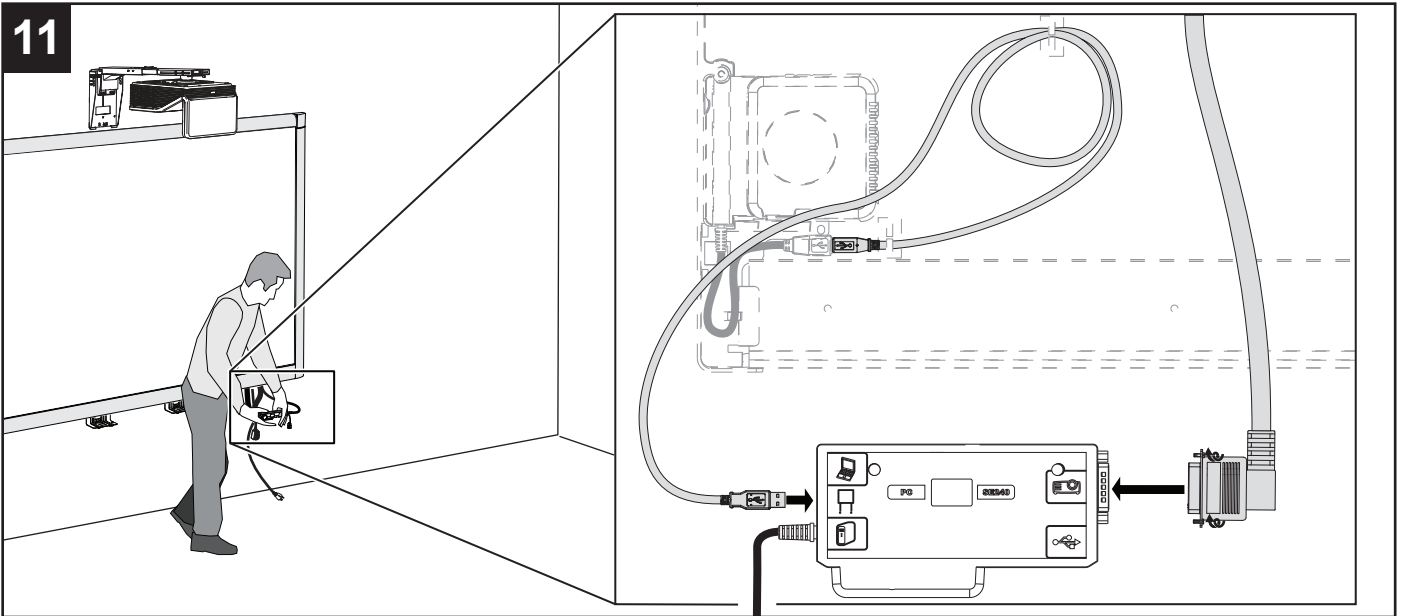

12

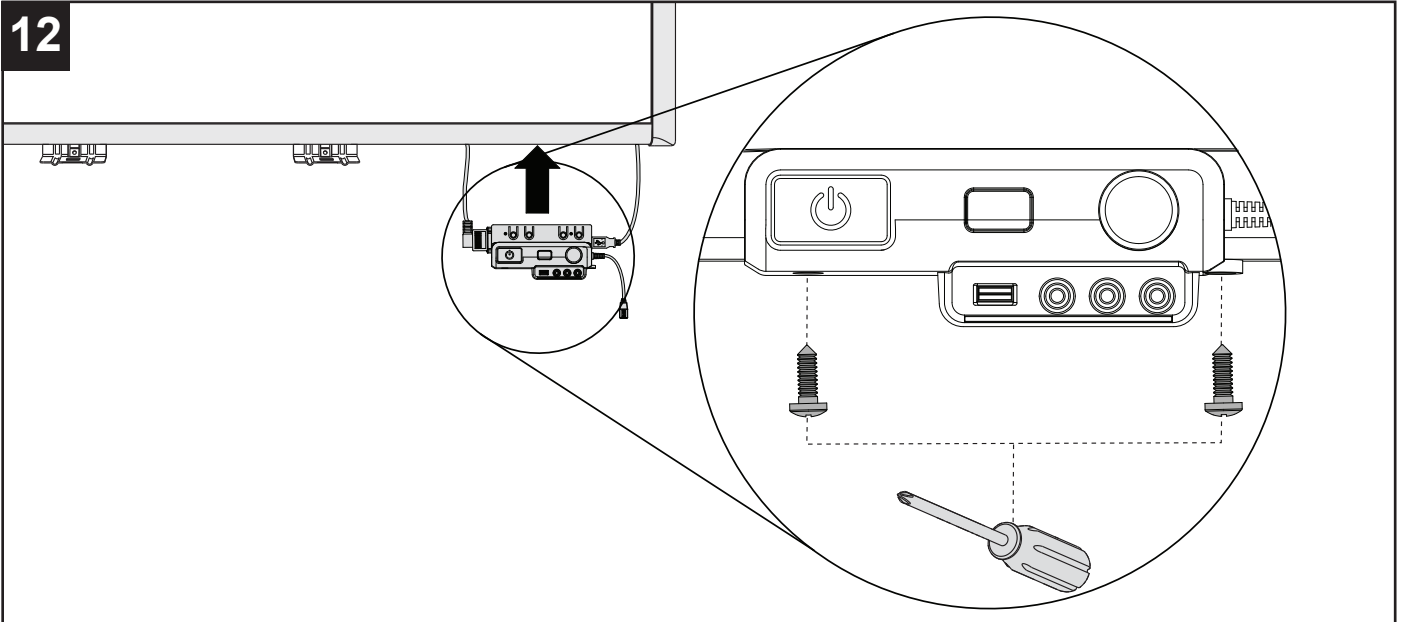

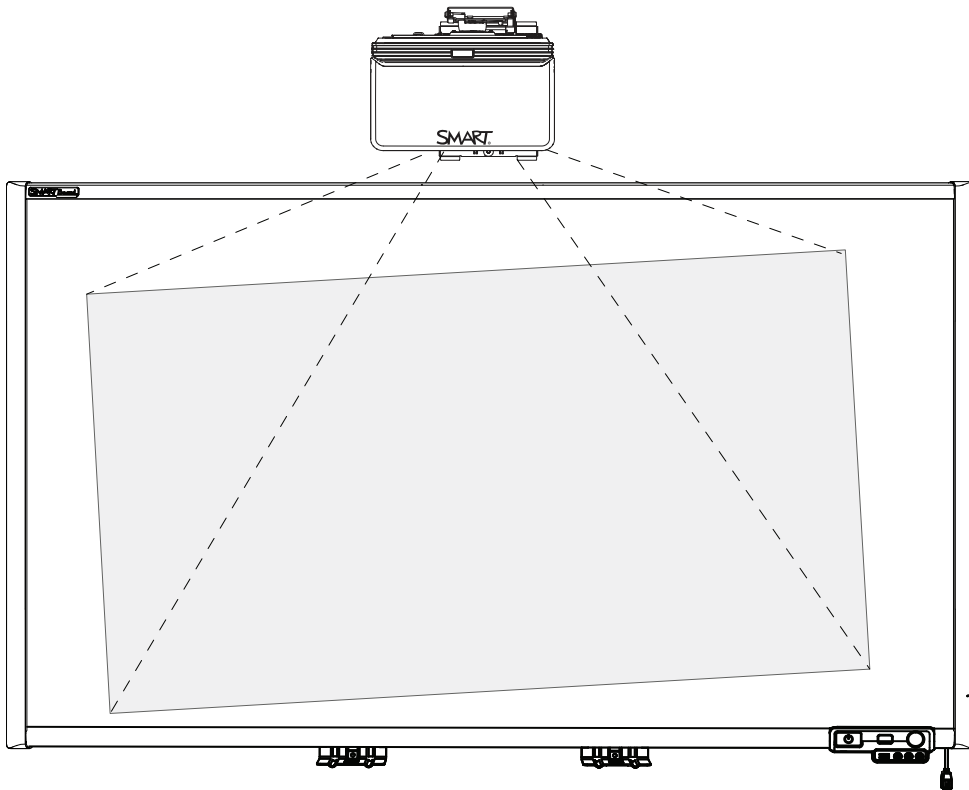

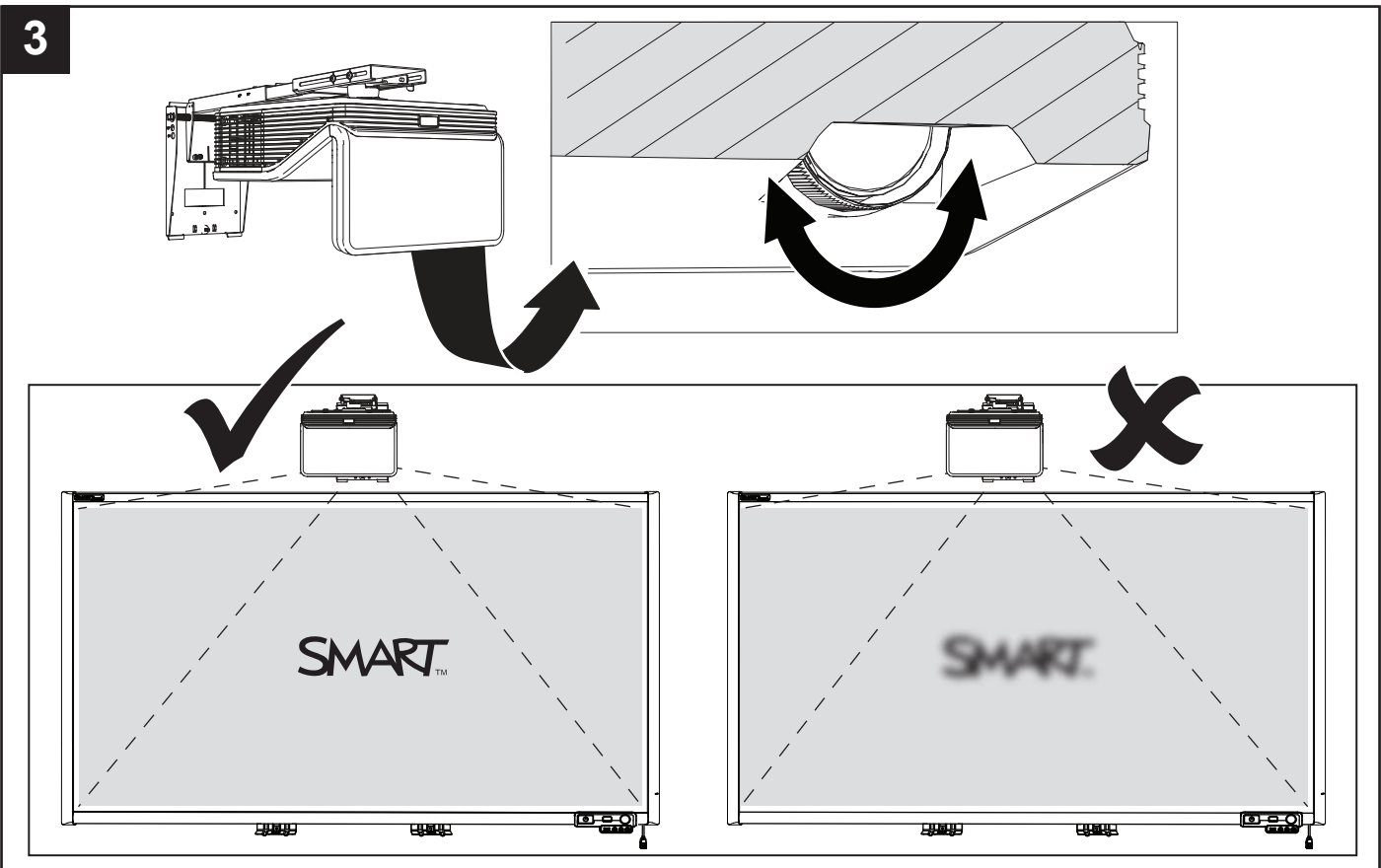
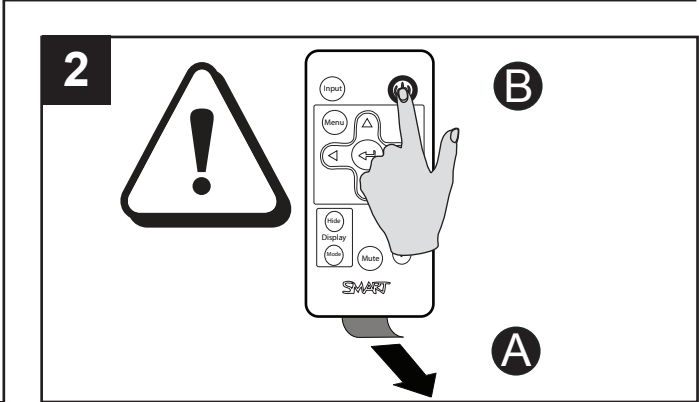
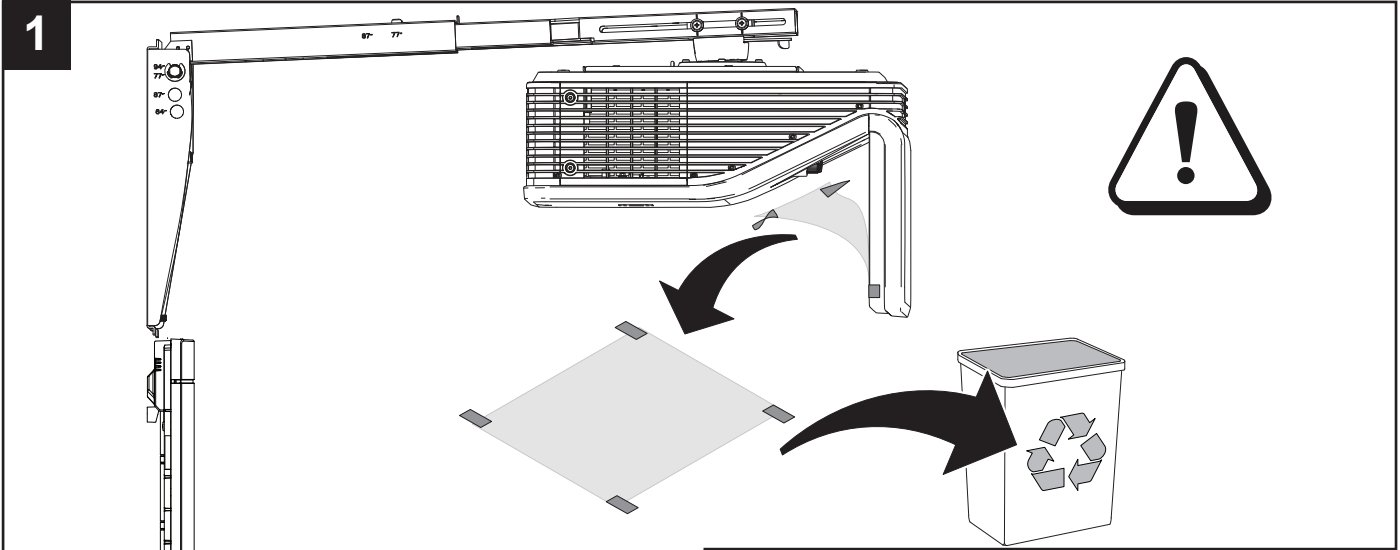

4

A

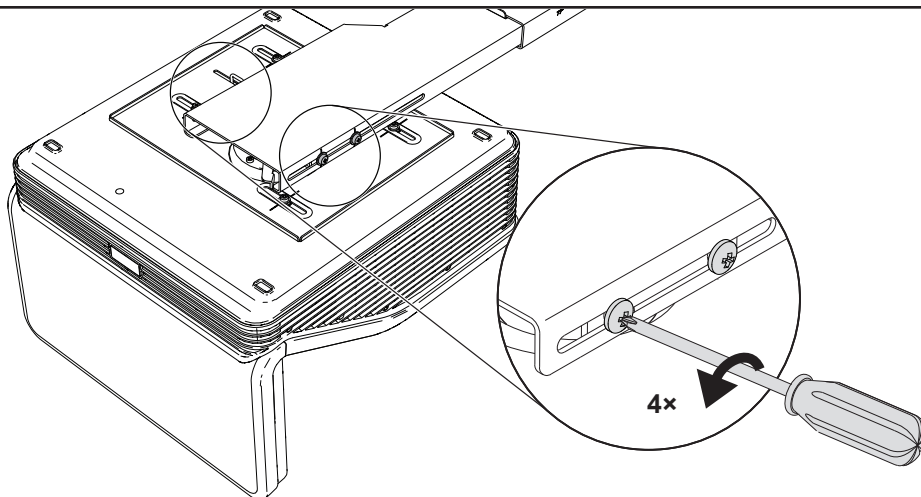

B

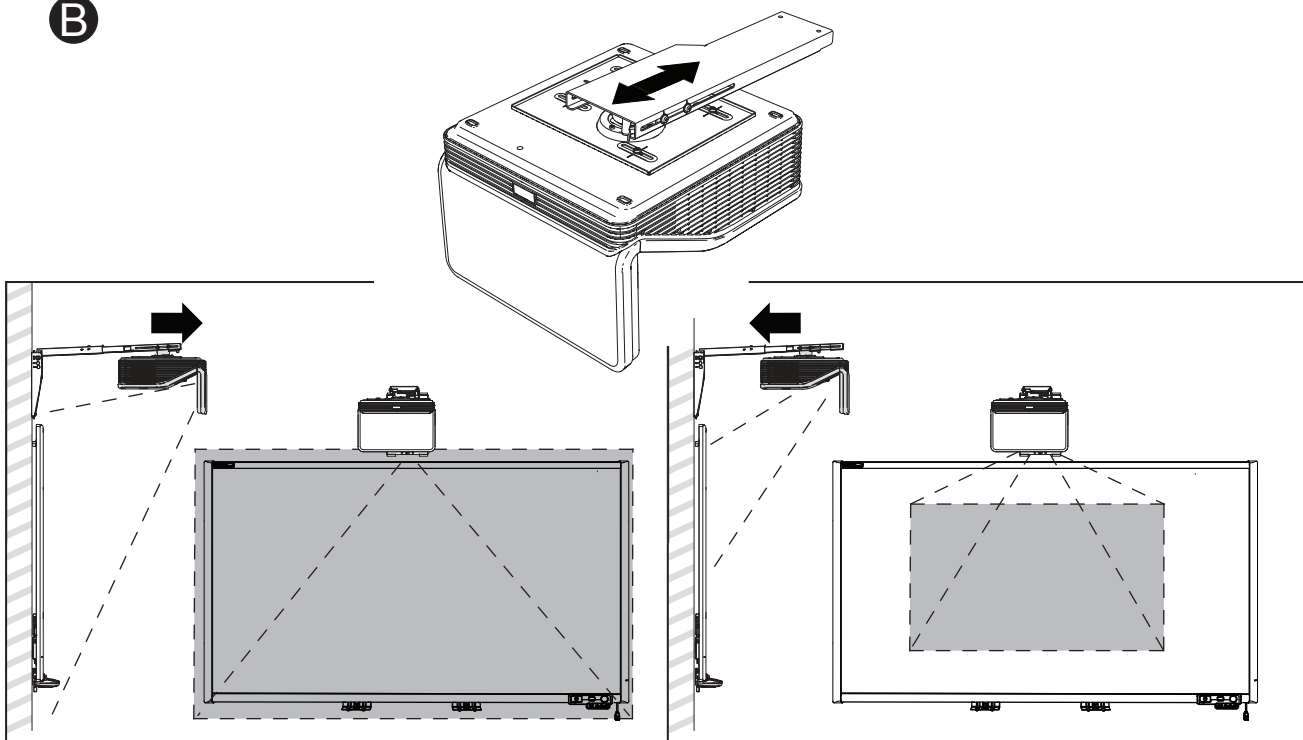

C

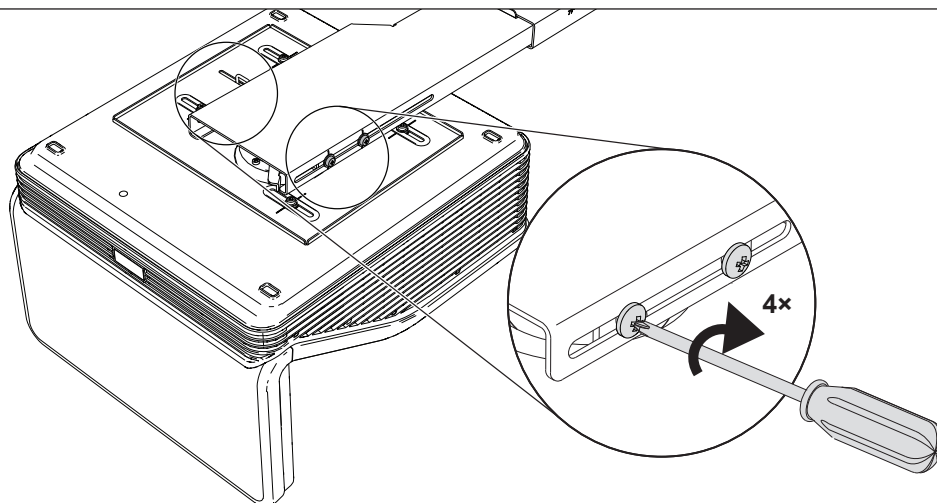

5

A

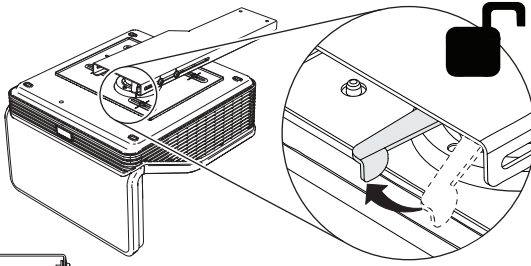

B

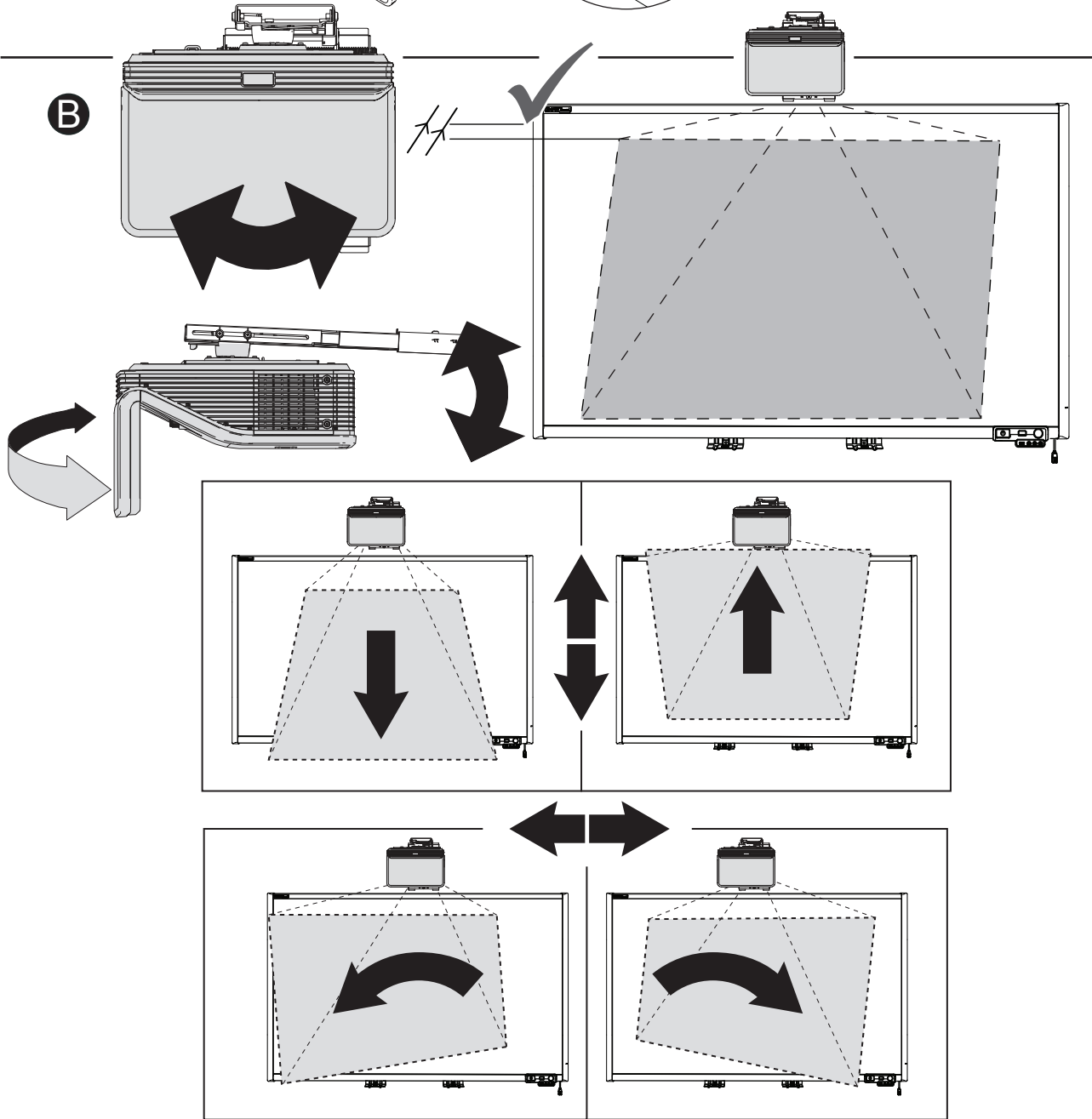

C

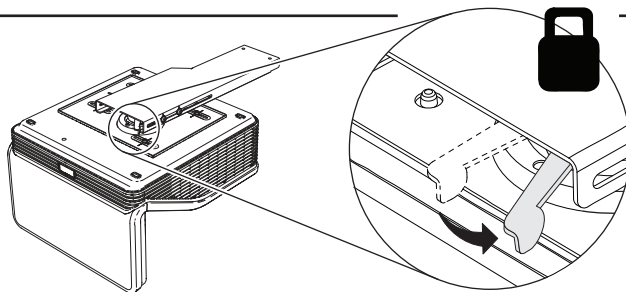

6

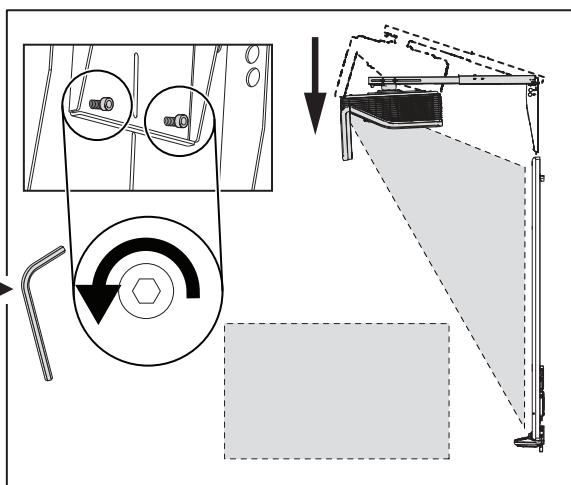
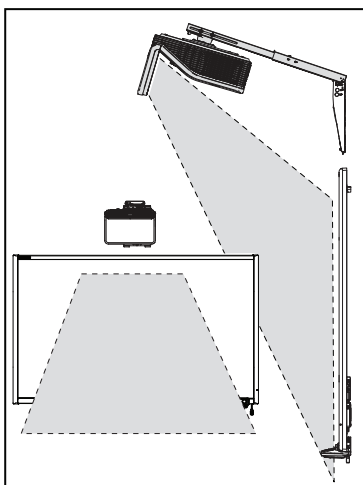
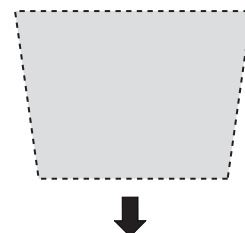
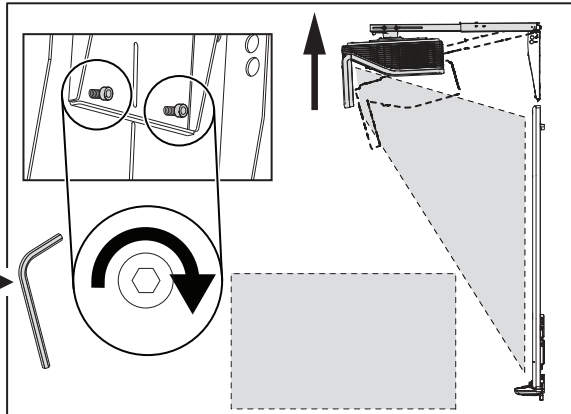
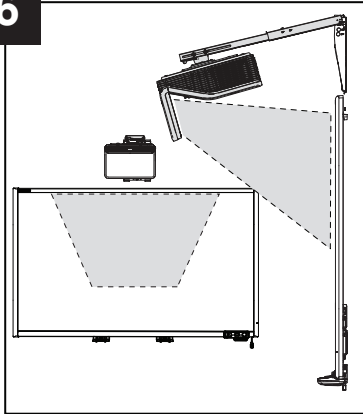

7

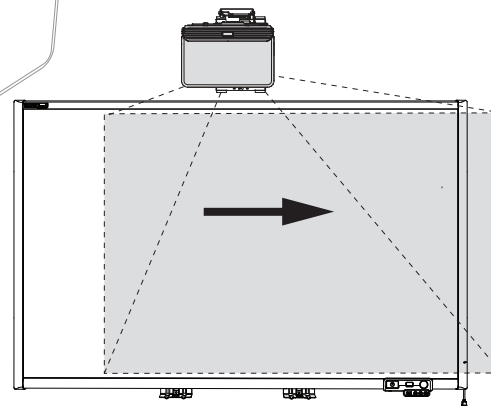
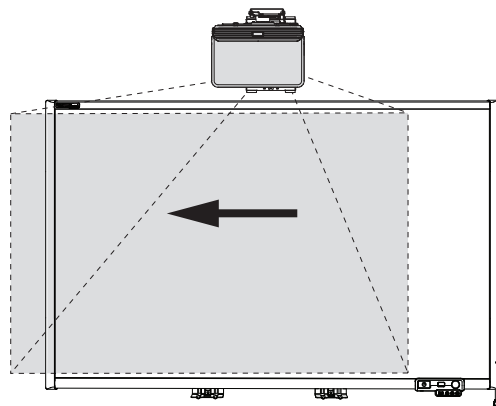
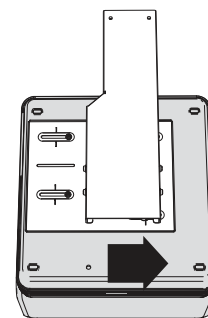
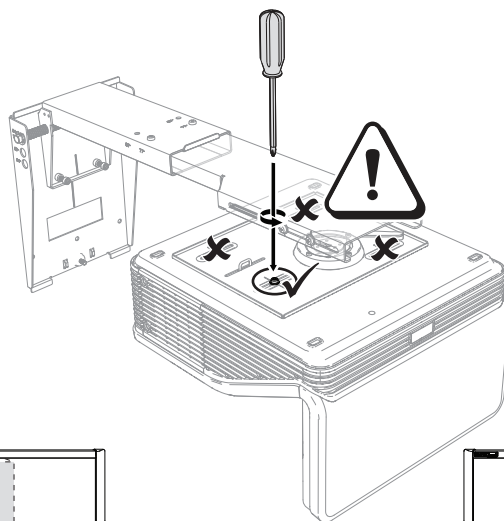
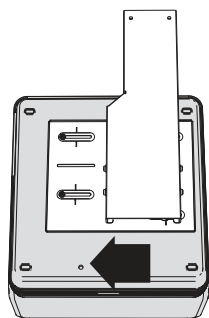

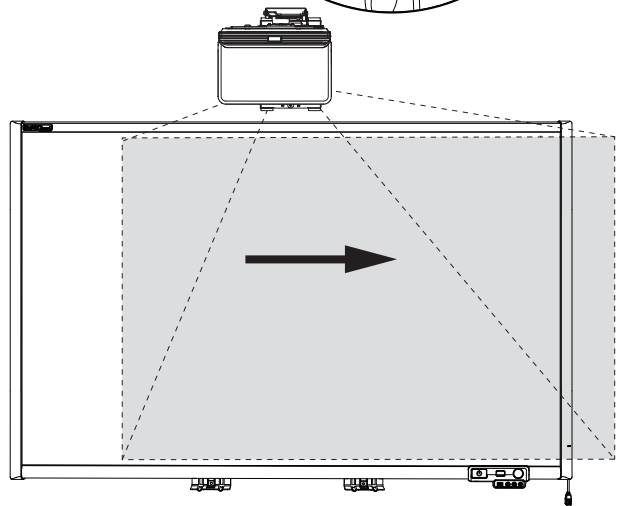
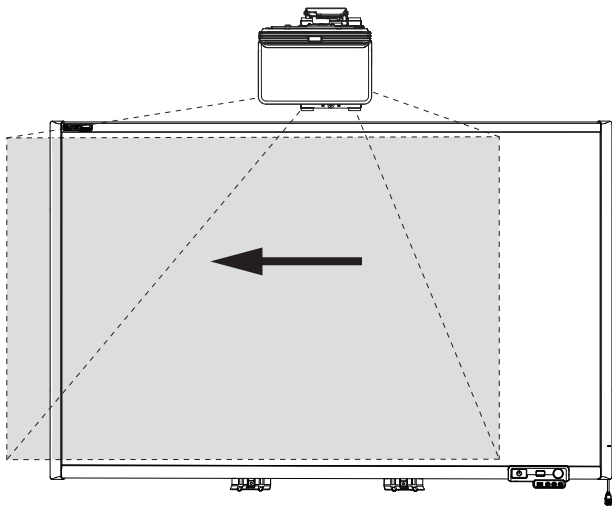
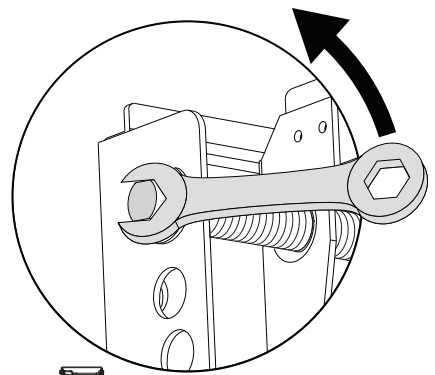
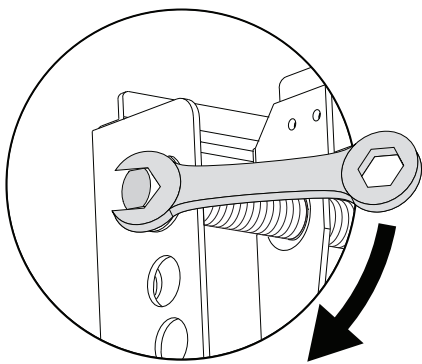
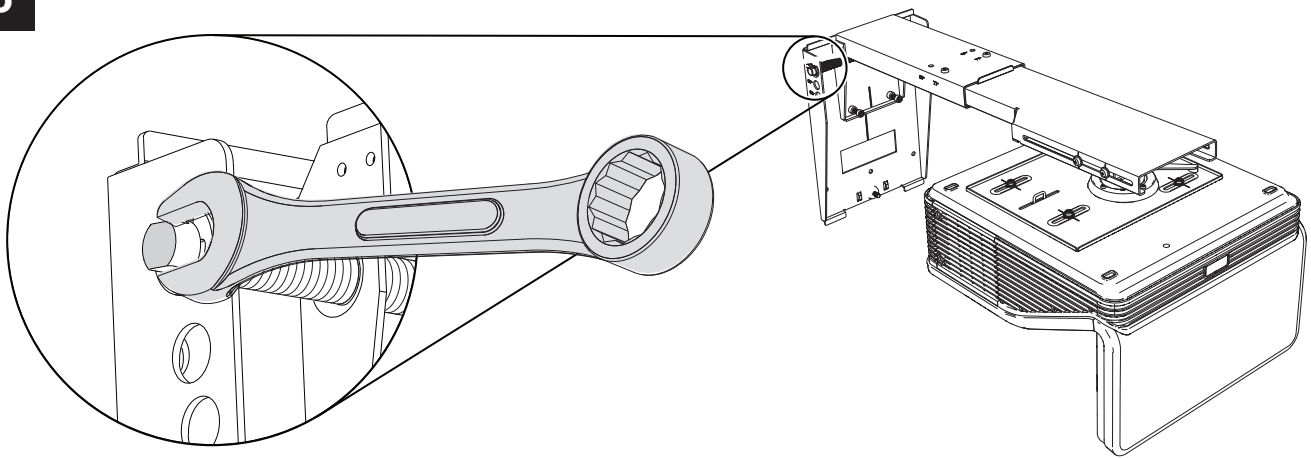

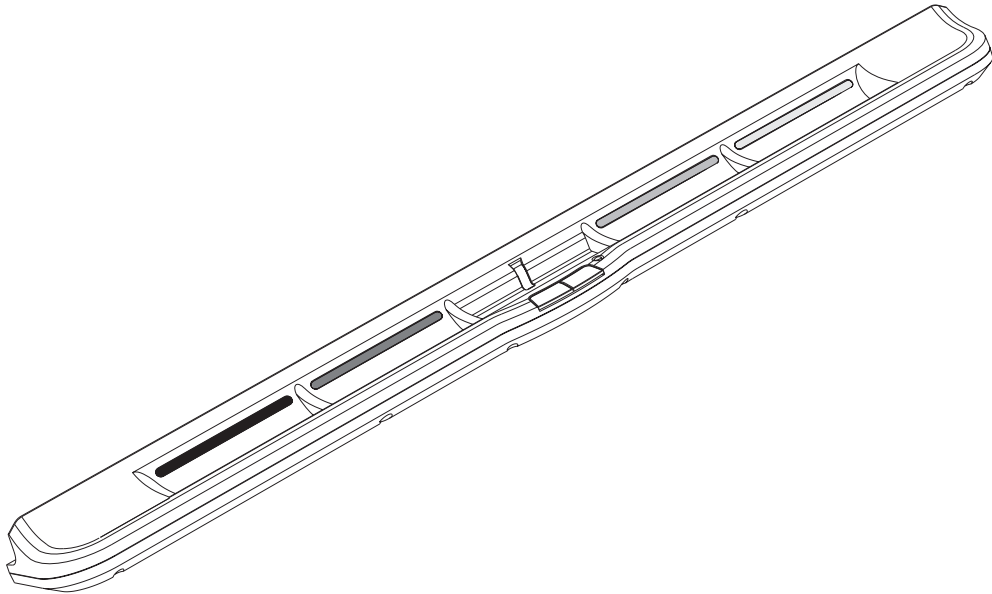

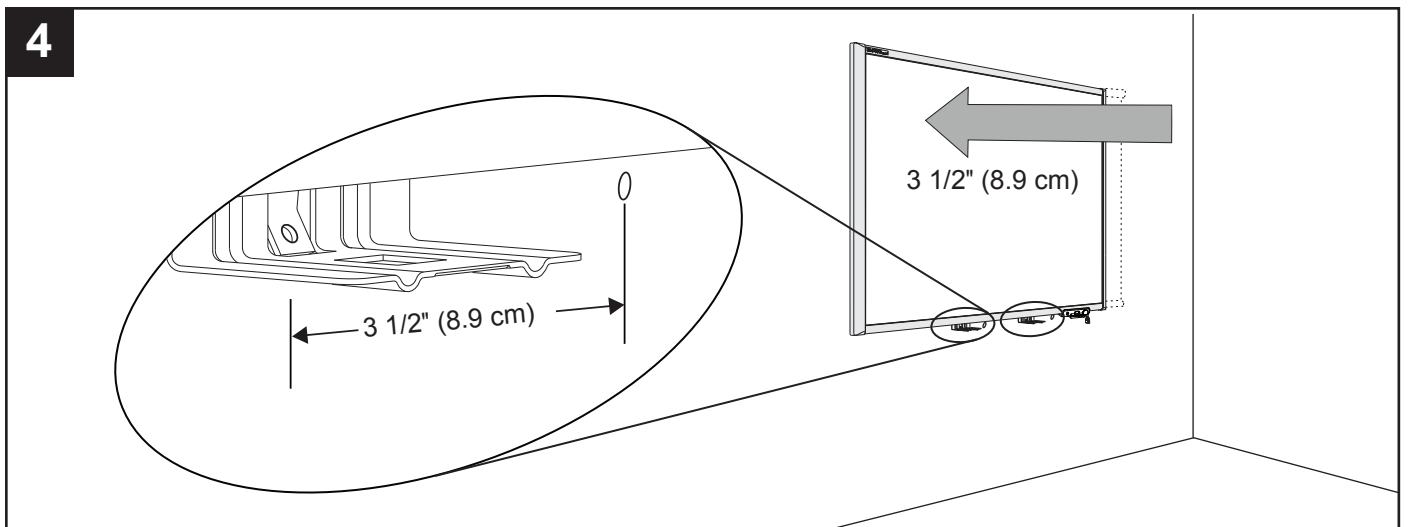
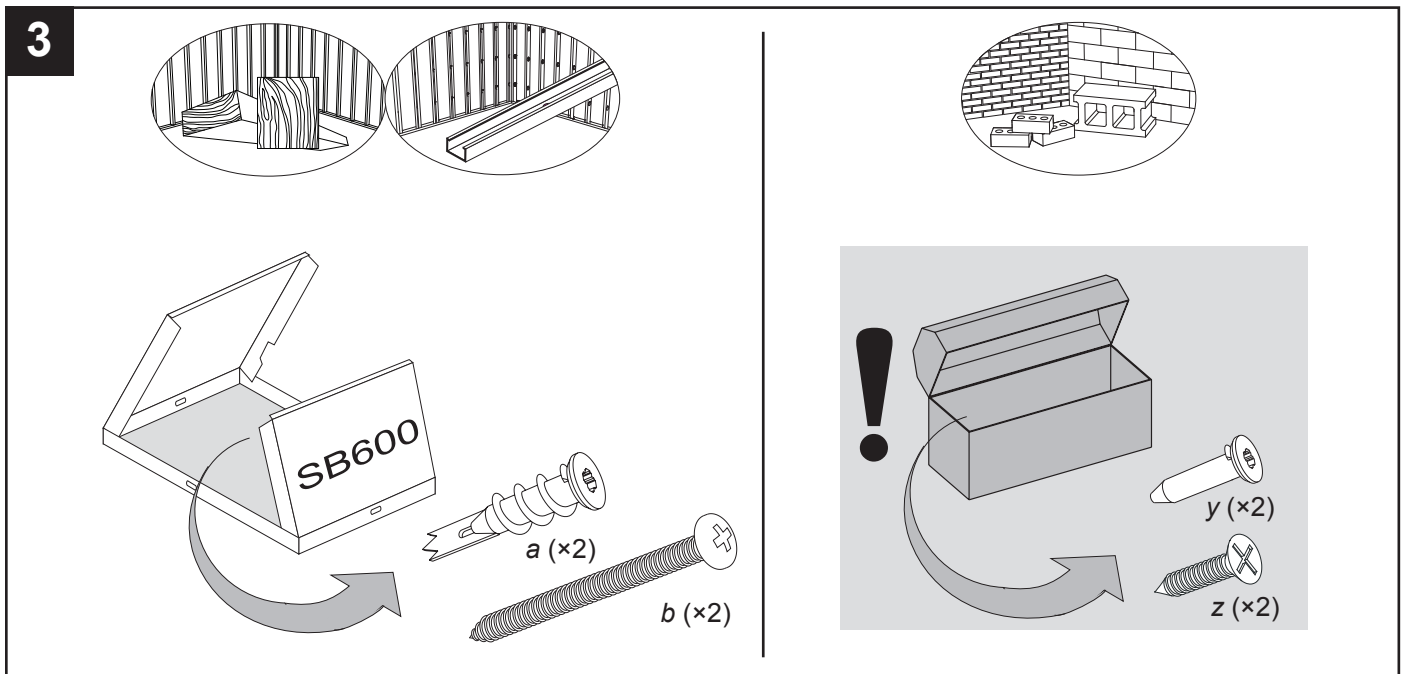
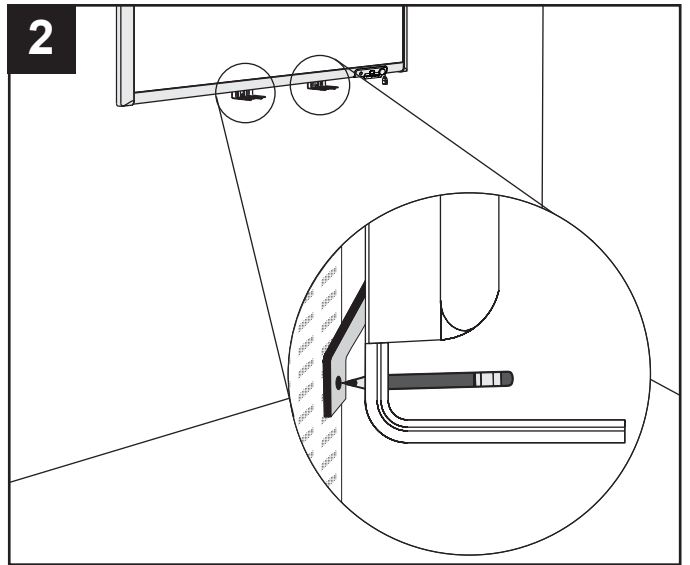
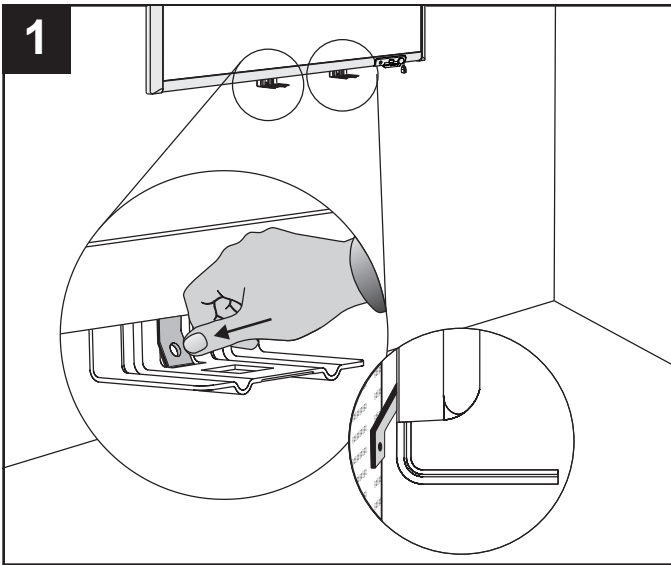

5

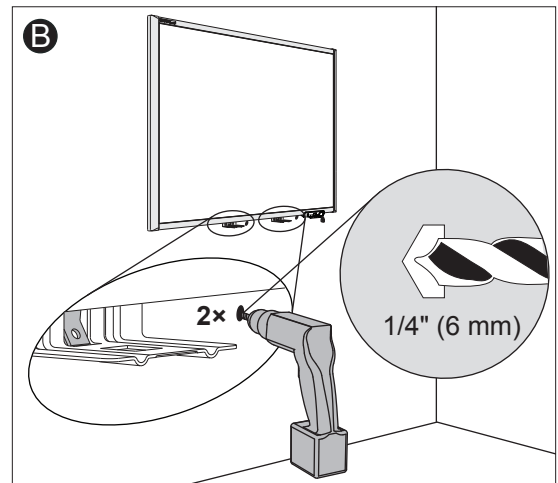
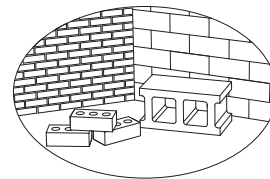
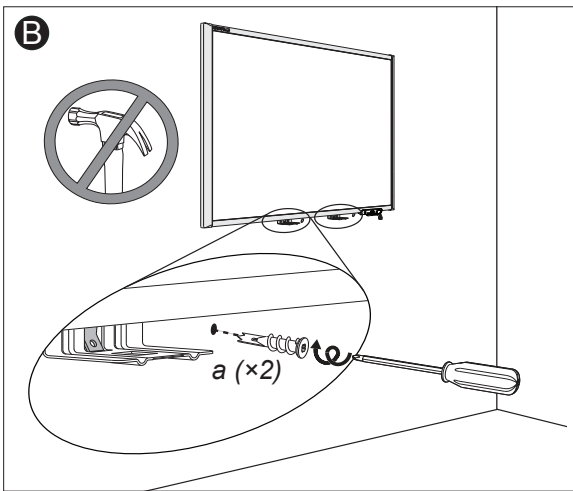
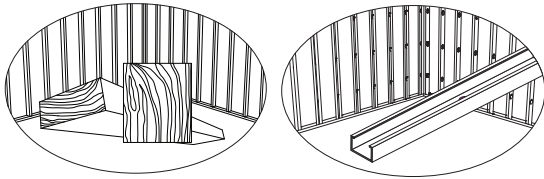

6

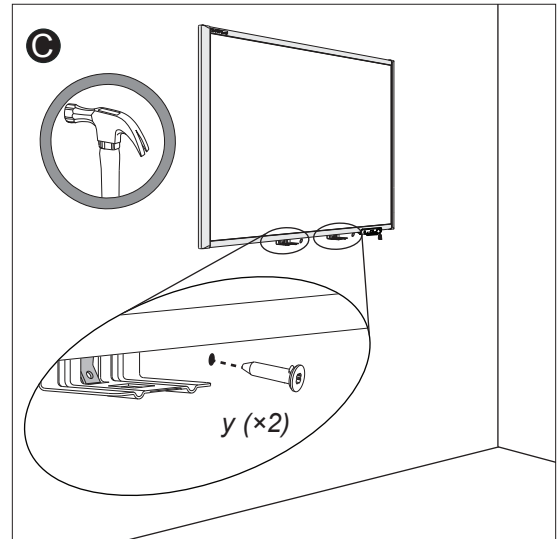
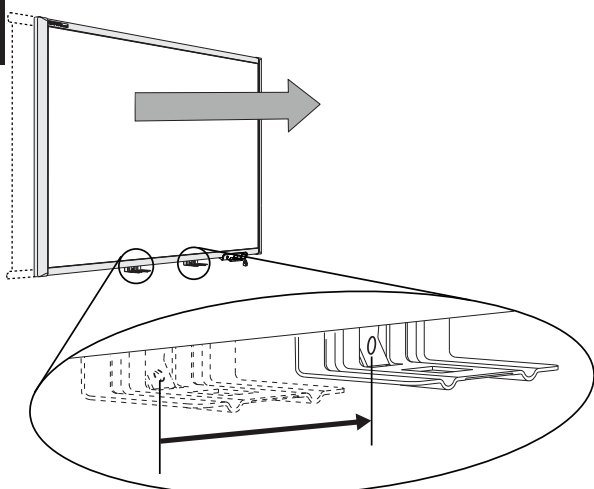

7

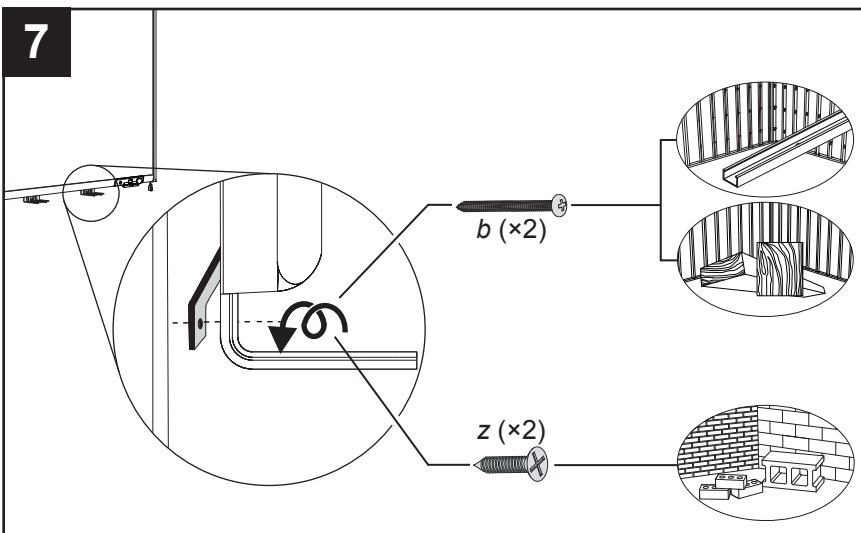

8

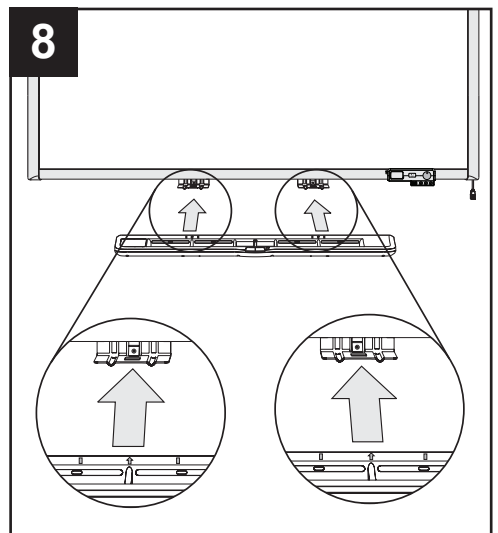

9

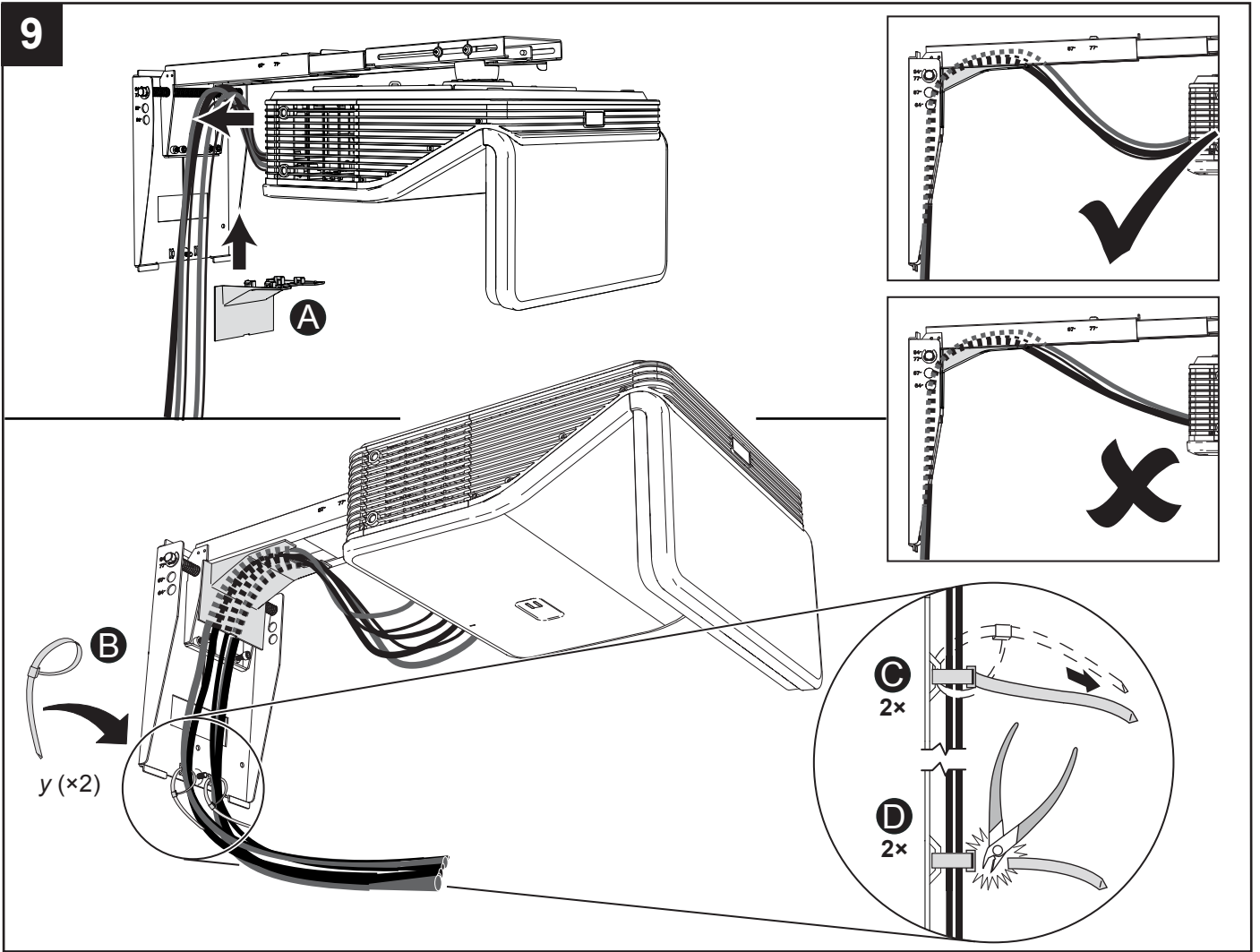

10

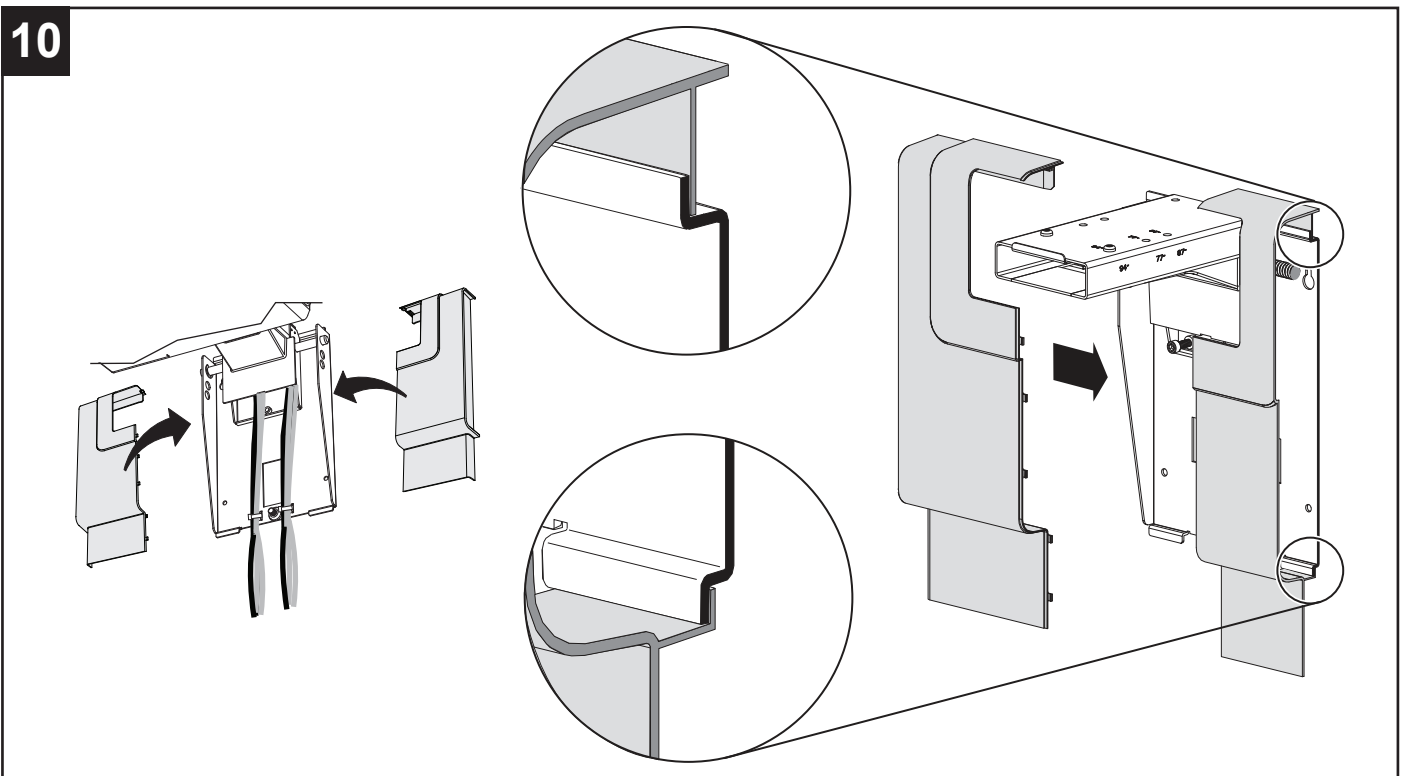

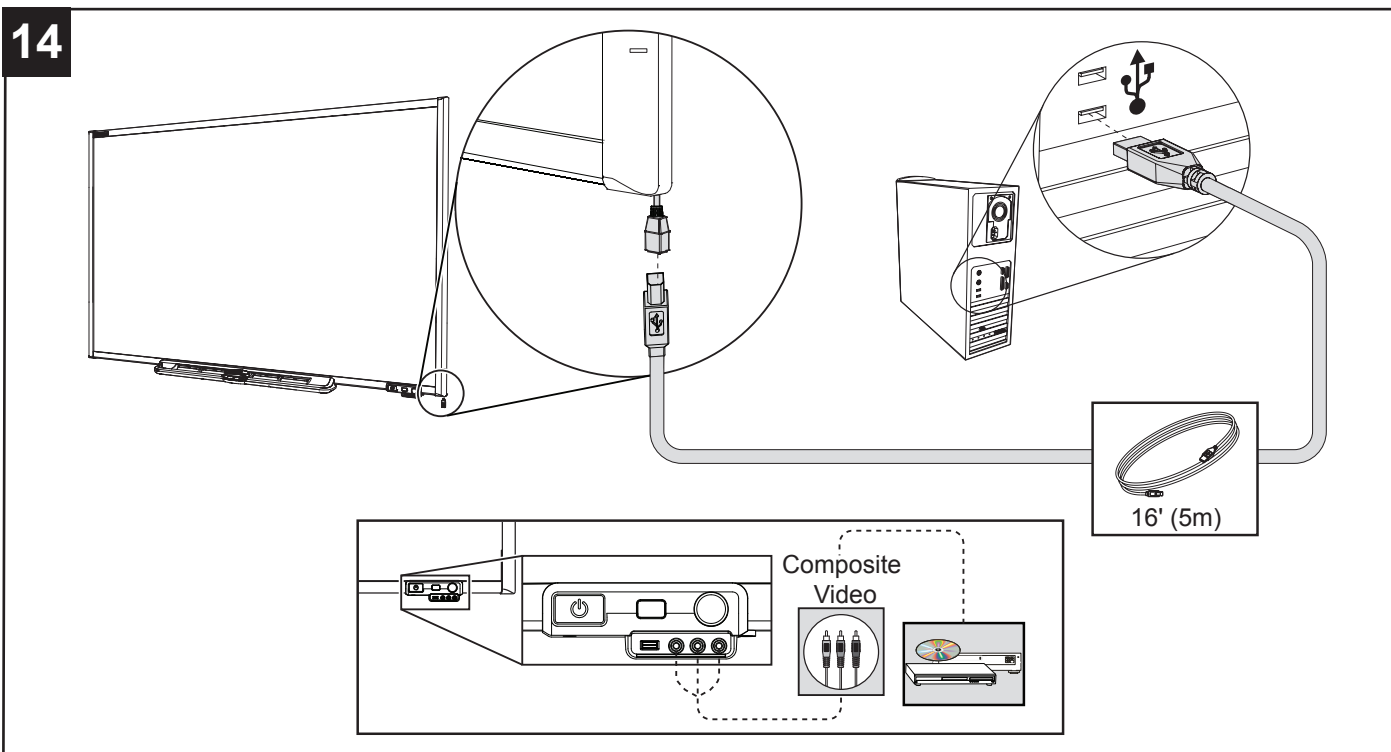
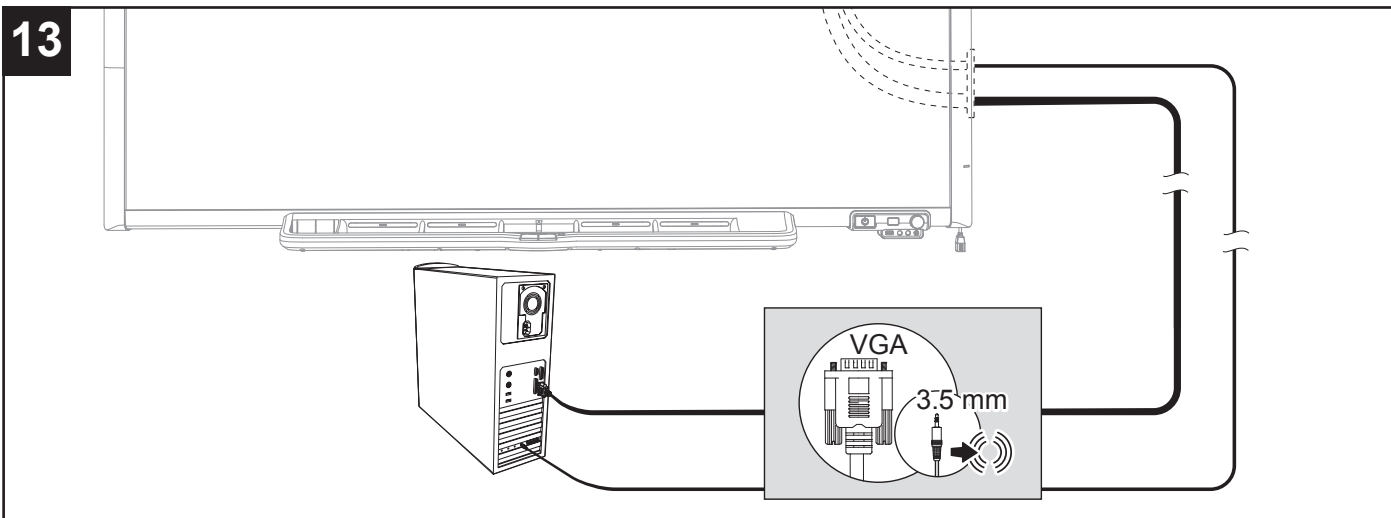
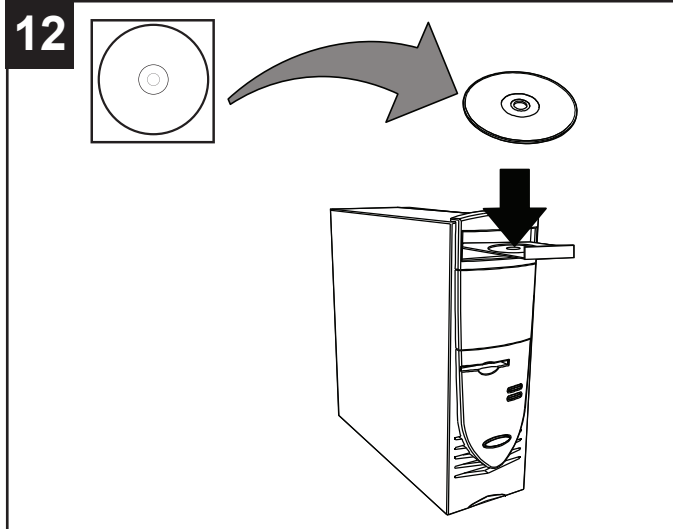
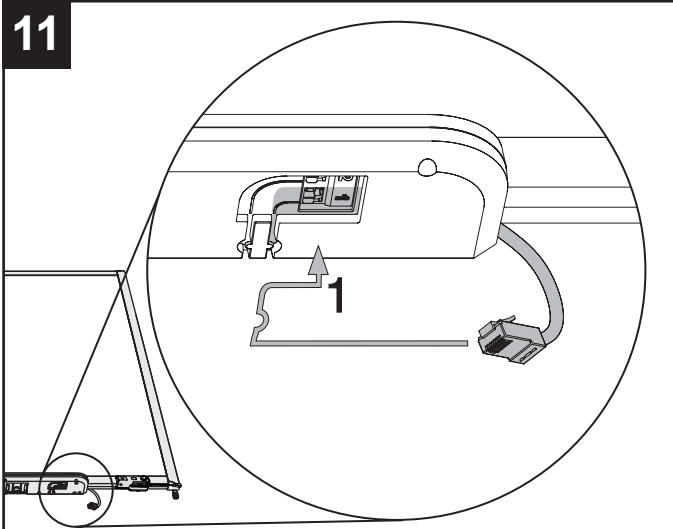

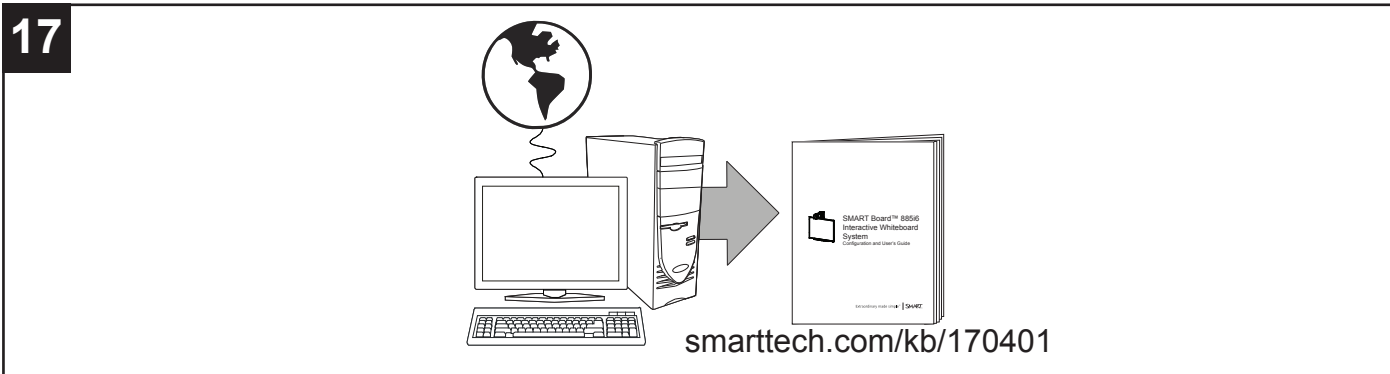
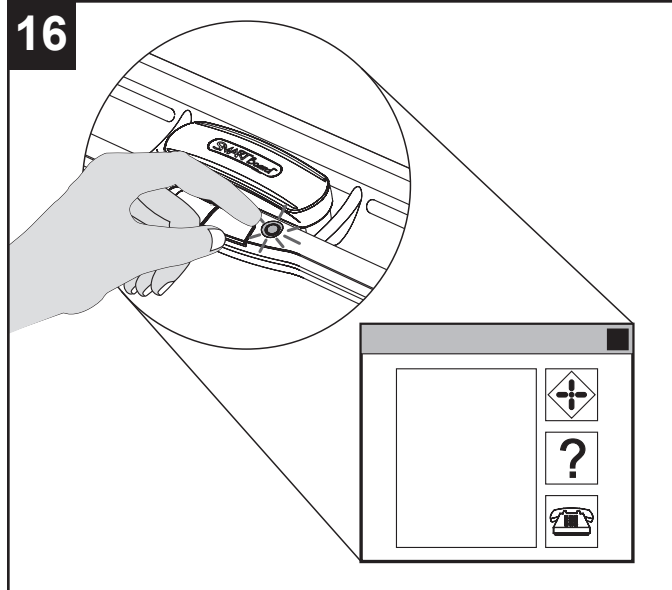
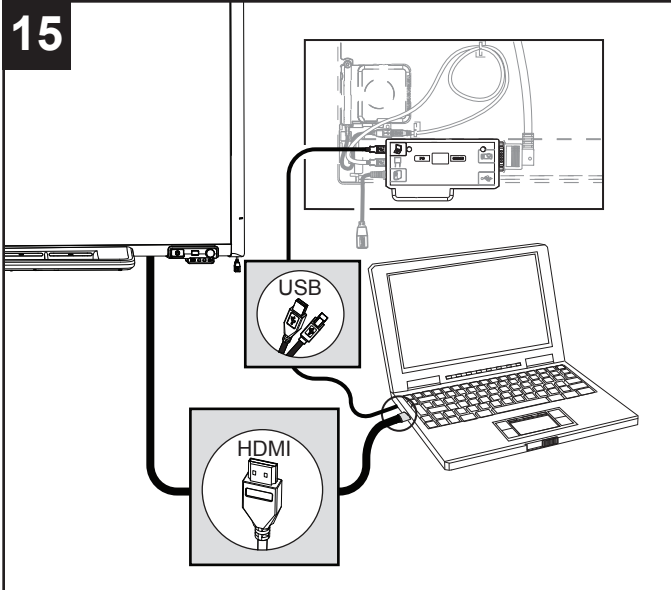

Hardware environmental compliance

SMART Technologies supports global efforts to ensure that electronic equipment is manufactured, sold and disposed of in a safe and environmentally friendly manner.



Waste Electrical and Electronic Equipment and Battery regulations (WEEE and Battery Directives)

Electrical and electronic equipment and batteries contain substances that can be harmful to the environment and to human health. The crossed-out wheeled bin symbol indicates that products should be disposed of in the appropriate recycling stream and not as regular waste.

Batteries

Remote contains CR2025 battery. Recycle or dispose of batteries properly.

Perchlorate Material

Remote battery contains perchlorate material. Special handling may apply.

See dtsc.ca.gov/hazardouswaste/perchlorate.



Mercury

The lamp in this product contains mercury and must be recycled or disposed in accordance with local, state, provincial or federal laws.

See smarttech.com/compliance for more information



smarttech.com/support
smarttech.com/contactsupport

