

PLEASE THINK BEFORE YOU PRINT

Specifications

SMART Mobile Height-Adjustable Floor Stand

Model FS-UX

Physical Specifications

Size

Without SMART Board™
interactive whiteboard

Wall mount
43 1/2" W × 58" H × 7" D
(110 cm × 147 cm × 17.7 cm)

Floor stand
69" W × 61 3/4" H × 39 1/4" D
(175 cm × 157 cm × 100 cm)

Weight

Without SMART Board
interactive whiteboard

Wall mount
98 lb. (44.4 kg)

Floor stand
184 lb. 8 oz. (83.5 kg)

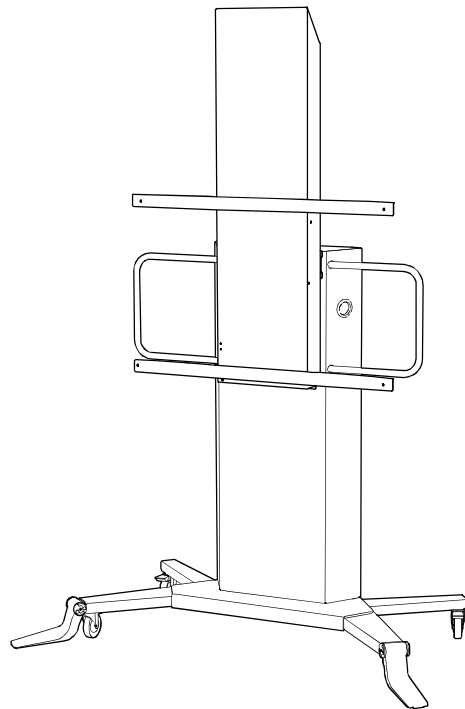

i NOTE:

See the [SMART Board interactive whiteboard page](https://www.smarttech.com/support) at [smarttech.com/support](https://www.smarttech.com/support) for your interactive whiteboard's specifications.

All dimensions +/- 1/8" (0.3 cm). All weights +/- 2 lb. (0.9 kg).

Extraordinary made simple™

SMART™

Shipping size

Without SMART Board interactive whiteboard	Wall mount
	21 3/4" W x 61 3/4" H x 7 1/4" D (55.2 cm x 156.8 cm x 18.4 cm)
	Floor stand
	38" W x 59" H x 9" D (96.5 cm x 149.9 cm x 22.9 cm)

Shipping weight

Without SMART Board interactive whiteboard	Wall mount
	110 lb. (49.9 kg)
	Floor stand
	215 lb. (97 kg)

Standard features

Adjustable height

25" (63 cm) of vertical travel allows you to raise or lower the interactive whiteboard to a convenient height.

With SMART Board 660
interactive whiteboard

- Reach points for the floor stand with this interactive whiteboard:

Interactive

whiteboard position	Lowest reach point	Highest reach point
Lowest position	19" (48 cm)	57 1/2" (146 cm)
Highest position	44" (112 cm)	82 1/2" (210 cm)

With SMART Board
680, 685, 880 or 885
interactive whiteboard

- Reach points for the floor stand mounted with these interactive whiteboards:

Interactive

whiteboard position	Lowest reach point	Highest reach point
Lowest position	11 1/4" (28 cm)	57 1/2" (146 cm)
Highest position	36 1/4" (92 cm)	82 3/8" (209 cm)

NOTE

Reach point refers to the height of the SMART Board interactive whiteboard's touchable screen (see page 5 for more information).

Power source

You can set the voltage switch to either 115V AC or 230V AC.

Product uses 100 W while raising or lowering your interactive whiteboard and 3 W while in standby mode.

Security

Height-adjustable mount automatically locks in position

Mobility

The floor stand prominently features two vertical grab bars which enable you to easily move the unit. The self-contained system rolls on 4" (10 cm) heavy-duty, non-marking, locking casters.

System stability	The mobile floor stand is equipped with locking anti-tip feet compliant with CSA/CE safety requirements. Its wide footprint and reinforced steel frame provide excellent stability for writing on or touching your interactive product.
Room-to-room mobility (SMART UX60 projector systems only)	Pivots through a 30" (76 cm) doorway  IMPORTANT When used with a SMART UF55 or UF65 projector, the floor stand is intended for in-room mobility only. The length of the projector boom on these models prevents them from passing through standard doorways.
Environmental compliance	China EIP, EU WEEE, EU RoHS, US CPSIA and packaging
Regulatory certification	CSA, CE, C-Tick and FCC
Warranty	Two-year limited equipment warranty

Storage and operating specifications

Operating temperature	Operating temperature range depends on your projector and interactive whiteboard. See your product documentation for more information.
Storage temperature	-40°F to 140°F (-40°C to 60°C)
Humidity	95°F (35°C) with up to 85% relative humidity, non-condensing

SMART order numbers

FS-UX	Mobile height-adjustable floor stand solution for SMART Board interactive whiteboards. This product includes both the height-adjustable wall mount and floor stand.
FS-UX-LTS	Optional laptop shelf for the FS-UX mobile floor stand
SMART UX60 projector systems	When combined with the mobile floor stand, these systems allow for room-to-room mobility.
SB685ix	SMART Board 685ix interactive whiteboard system (includes a SMART Board 685 interactive whiteboard integrated with a SMART UX60 ultra-short-throw projector)
SBD685ix	SMART Board D685ix interactive whiteboard system (includes a Dual-Touch/Dual-Write SMART Board 685 interactive whiteboard integrated with a SMART UX60 ultra-short-throw projector)
SBX885ix	SMART Board X885ix interactive whiteboard system (includes a SMART Board X885 interactive whiteboard integrated with a SMART UX60 ultra-short-throw projector)
SBA-L	Optional speakers for SMART Board 685ix and X885ix interactive whiteboard systems

**SMART UF55
projector systems**

When combined with the mobile floor stand, these systems allow for in-room mobility only.

- SB660i3 SMART Board 660i3 interactive whiteboard system (includes a SMART Board 660 interactive whiteboard integrated with a SMART UF55 projector)
- SB680i3 SMART Board 680i3 interactive whiteboard system (includes a SMART Board 680 interactive whiteboard integrated with a SMART UF55 projector)
- SB685i3 SMART Board 685i3 interactive whiteboard system (includes a SMART Board 685 interactive whiteboard integrated with a SMART UF55 projector)
- SBD680i3 SMART Board D680i3 interactive whiteboard system (includes a dual-touch/dual-write SMART Board 680 interactive whiteboard integrated with a SMART UF55 projector)
- SBD685i3 SMART Board D685i3 interactive whiteboard system (includes a dual-touch/dual-write SMART Board 685 interactive whiteboard integrated with a SMART UF55 projector)
- SBA Optional speakers for SMART UF55 projector systems

**SMART UF65
projector systems**

When combined with the mobile floor stand, these systems allow for in-room mobility only.

- SB660i4 SMART Board 660i4 interactive whiteboard system (includes a SMART Board 660 interactive whiteboard integrated with a SMART UF65 projector)
- SB680i4 SMART Board 680i4 interactive whiteboard system (includes a SMART Board 680 interactive whiteboard integrated with a SMART UF65 projector)
- SBD680i4 SMART Board D680i4 interactive whiteboard system (includes a dual-touch/dual-write SMART Board 680 interactive whiteboard integrated with a SMART UF65w projector)
- SBD685i4 SMART Board D685i4 interactive whiteboard system (includes a dual-touch/dual-write SMART Board 685 interactive whiteboard integrated with a SMART UF65w projector)
- SBX880i4 SMART Board X880i4 interactive whiteboard system (includes a SMART Board X880 interactive whiteboard integrated with a SMART UF65 projector)
- SBX885i4 SMART Board X885i4 interactive whiteboard system (includes a SMART Board X885 interactive whiteboard integrated with a SMART UF65 projector)
- SBA-L Optional speakers for SMART Board 685ix and X885ix interactive whiteboard systems and SMART UF65 projector systems

Mobility and maximum display dimensions

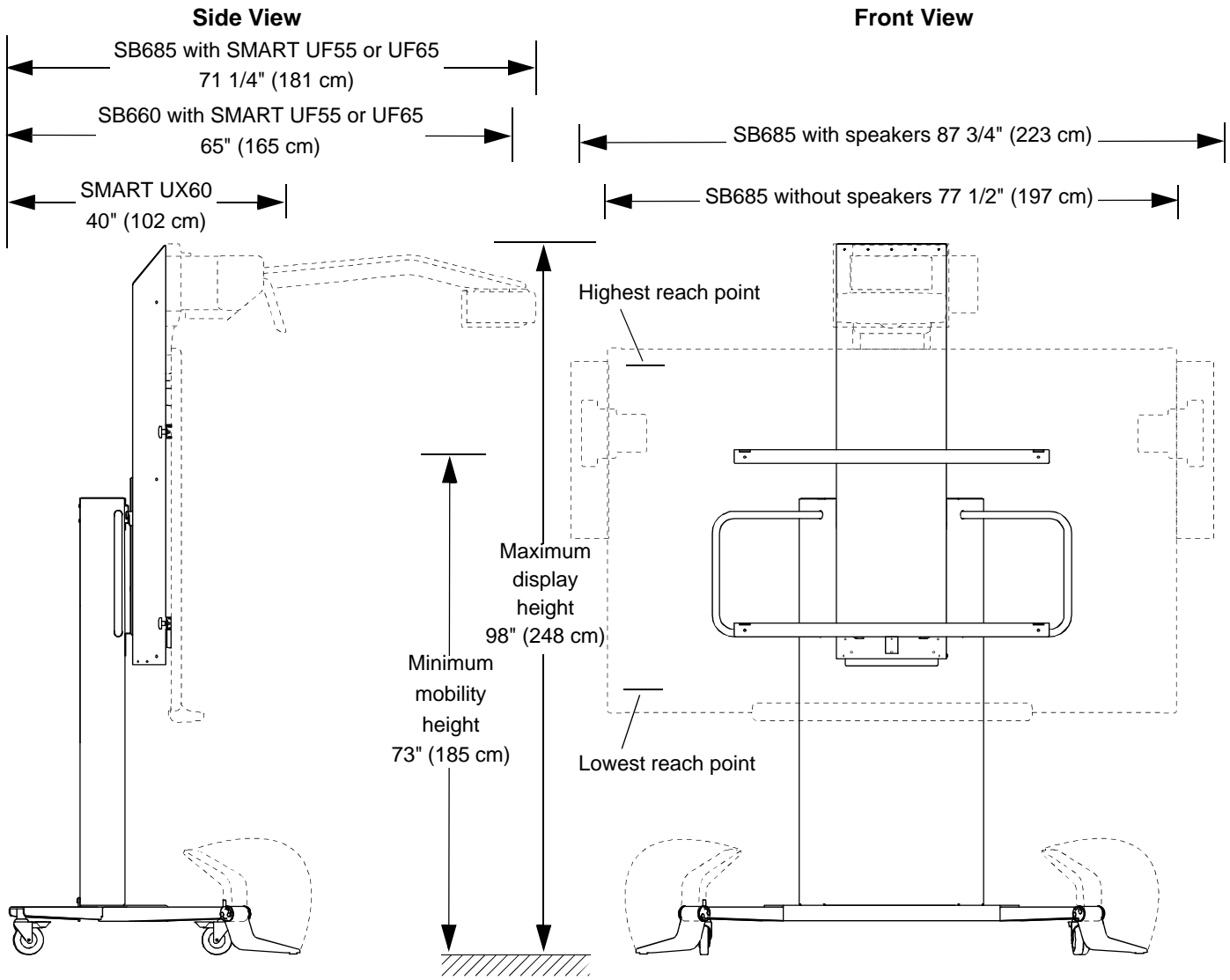

Back view (bottom cavity)

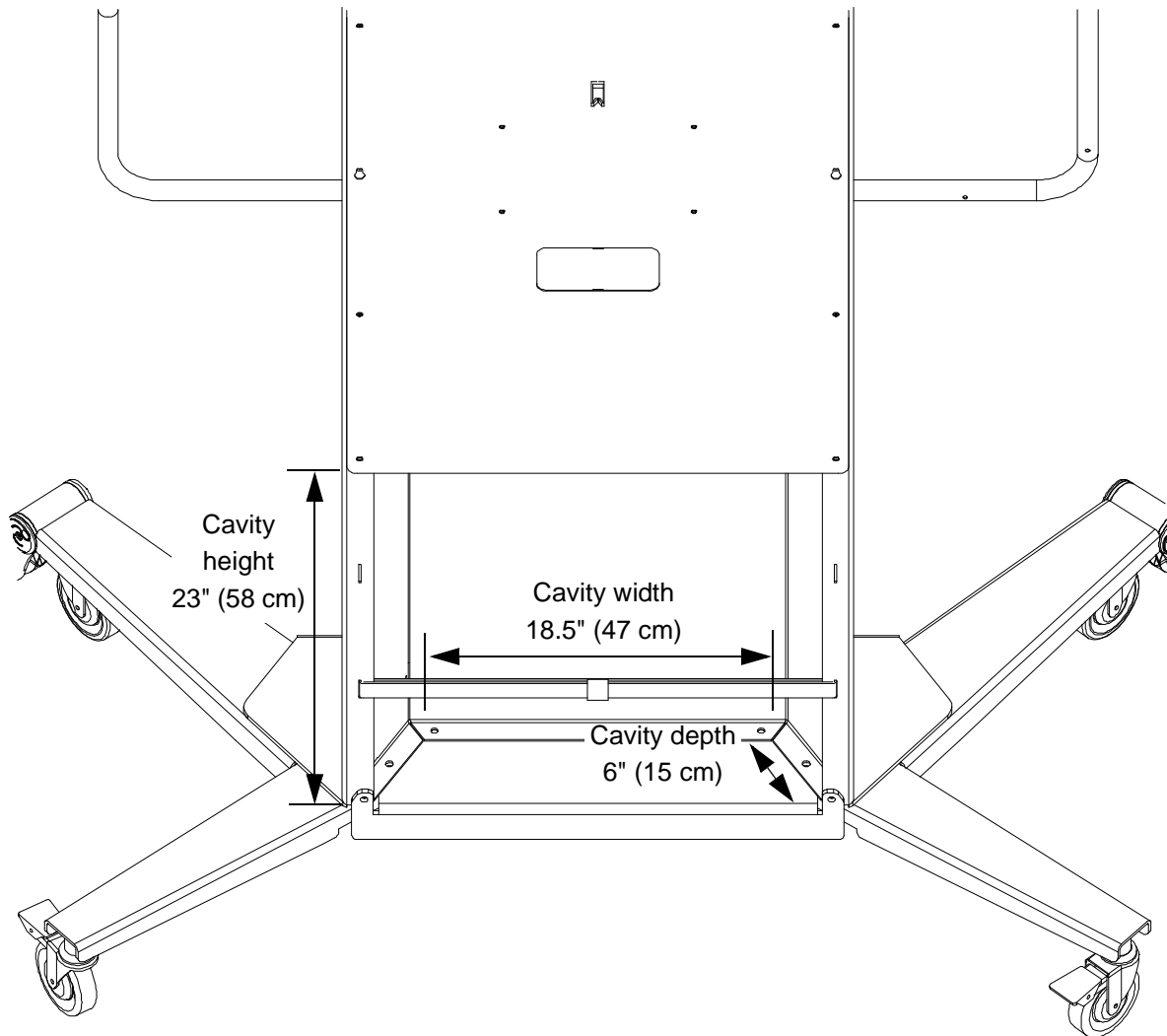

www.smarttech.com/support www.smarttech.com/contactsupport
Support +1.403.228.5940 or Toll Free 1.866.518.6791 (U.S./Canada)



© 2010 SMART Technologies ULC. All rights reserved. SMART Board, the SMART logo and smarttech are trademarks or registered trademarks of SMART Technologies ULC in the U.S. and/or other countries. All third-party product and company names may be trademarks of their respective owners. Patents pending. Contents are subject to change without notice. 11/2010.